









ATDEC Infinite Mounting Possibilities

Full Motion | Small swing arm **TH-1032-VFM**

-  Suits mounting hole sizes 75x75mm to 200x200mm (opt. support to 400x400)*
-  Flexible wall mount
-  Suits displays up to 25kgs (55lbs)
-  Swing arm wall extension
-  Tool-less tilt & pan adjustment
-  Allows positional adjustment
-  User adjustable screen orientation
-  Quick Release mounting head

The Small Swing Arm is a cutting edge wall mount with superior styling and extended operational flexibility for light weight displays. The Full Motion design allows your screen to be extended from the wall and rotated to the required viewing position. The mounting head supports a wide variety of VESA compatible monitors and TVs. The head features a ball joint that allows tilt/pan adjustment as well as landscape/portrait screen rotation. It features a Quick Release mechanism for easy display installation and maintenance with a security screw to deter theft. Once installed, your guaranteed a quality professional finish with fully integrated cable management and a dress cover to hide the wall connection.



Product key features:

- Suits a wide range of installation and usage situations
- Swing arm design enables wall extension from 90mm (3.5") to 245mm (9.6")
- Allows 180° rotation at the wall and 180° at the display head for viewing angle adjustment
- Quick Release mounting head enables easy installation and maintenance with a security screw (provided) to deter unauthorized removal.
- Integrated ball-joint allows +/-20° tilt/ pan adjustment and 360° screen rotation.
- Integrated cable management.
- Comes with all mounting hardware for masonry and timber stud installation.
- Durable construction with 10 year warranty.

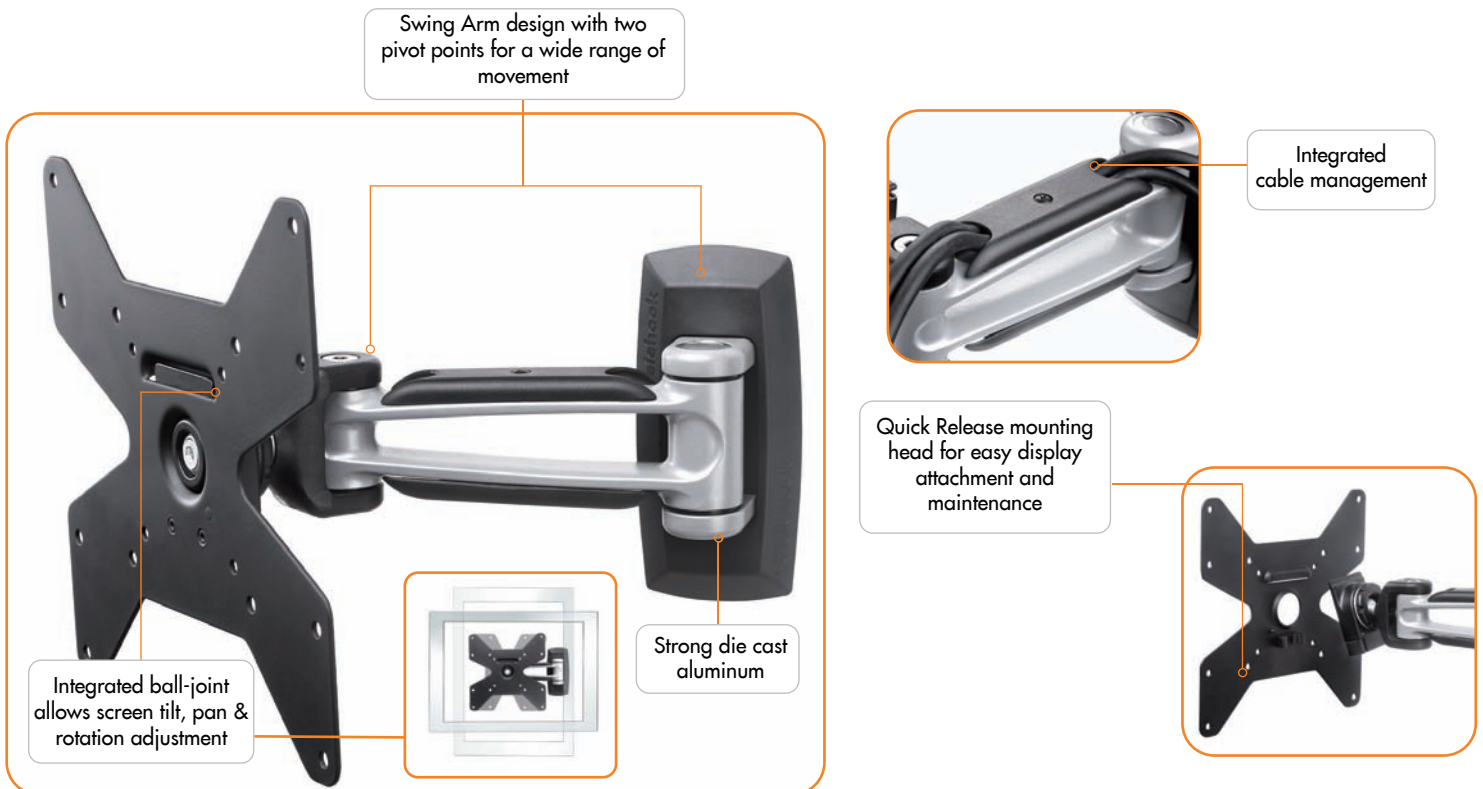

* Supports 75x75, 100x100, 200x100 & 200mmx200mm VESA hole patterns. Also supports 200x300, 200x400, 300x200, 300x300, 300x400, 400x200, 400x300 & 400mmx400mm via optional adaptor accessory

Product information, single unit

Model code	Ship weight	Material	Color
TH-1032-VFM	25kg (55lbs)	Die cast aluminium arm, steel wallplate & display bracket, plastic trim	Matt silver with black trim

Package information, single unit

Size	Ship weight	UPC code	Contents
22.5cm x 22.5cm x 10.5cm (8.7" x 7.5" x 2")	1.6kg (2.9lbs)	881493006386	Mount (pre-assembled), wall cover, security screw, install guide, display and wall attachment hardware

Package information, master pack

Size	Ship weight	UPC	Units per master pack
113.5cm x 23.5cm x 23.5cm (22.4" x 9.4" x 8.5")	17kg (30.36lbs)	881493004962	10

Technical drawings

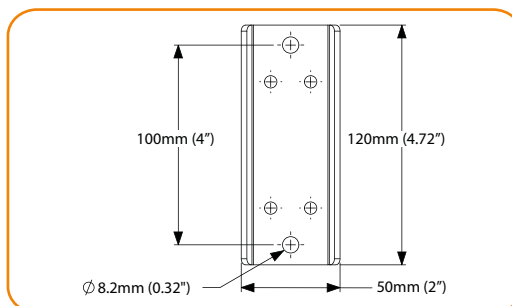
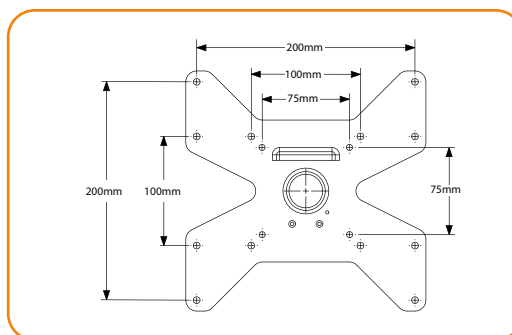
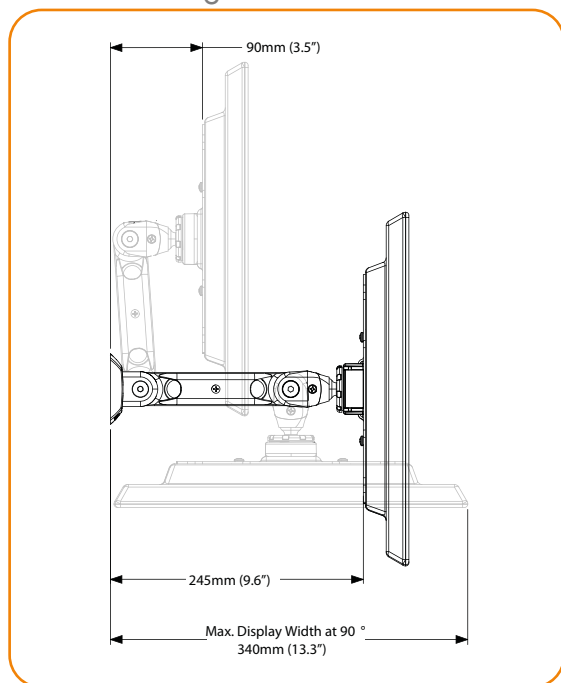

Accessory options

AC-AP-4040	400x400 VESA adaptor
------------	----------------------

Other models in this range

TH-1040-VFM	Low weight Full Motion articulated arm
TH-2050-VFM	Medium weight Full Motion articulated arm
TH-3270-UFM	High weight Full Motion articulated arm
TH-3060-SAU	High weight swing arm (silver)

Atdec mounts are designed, developed and tested in Australia. We manufacture an extensive range of display and projector mountings for a variety of user types and situations. While all efforts have been made to ensure the information in this brochure was correct as of the date of printing, we reserve the right to change specifications without notice. Please refer to the web site for our full range along with the latest details on specifications, compatibility and dealer location. Atdec and Telehook are registered trademarks with all rights reserved.