









Full Motion | Small articulated arm TH-1040-VFM

-  Suits mounting hole sizes 75x75mm to 200x200mm (opt. support to 400x400)*
-  Flexible wall mount
-  Suits displays up to 25kgs (55lbs)
-  Articulated wall extension
-  Toolless tilt & pan adjustment
-  Allows positional adjustment
-  User adjustable screen orientation
-  Quick Release mounting head

The Small Articulated Arm is a cutting edge wall mount with superior styling, enhanced operational flexibility with extended extended positional adjustment. The Full Motion design allows your display to be extended from the wall and rotated to the required viewing position. The mounting head supports a wide variety of VESA compatible monitors and TVs. The head features a ball joint that allows tilt/ pan adjustment and landscape / portrait screen rotation. It features a Quick Release mechanism for easy display installation and maintenance with a security screw to deter unauthorized removal. Once installed, your guaranteed a quality professional finish with fully integrated cable management and a dress cover to hide the wall connection.



Product key features:

- Suits a wide range of installation and usage situations.
- Articulated design enables a centralized seated position with wall extension from 102mm (4") out to 444mm (17.5").
- Allows 180° rotation at the wall, 360° at the articulation and 180° at the head
- Quick Release mounting head enables easy installation and maintenance with a security screw (provided) to deter unauthorized removal.
- Integrated ball-joint allows +/-20° tilt and pan adjustment and 360° screen rotation.
- Integrated cable management.
- Comes with all mounting hardware for masonry and timber stud installation.
- Durable construction with 10 year warranty.

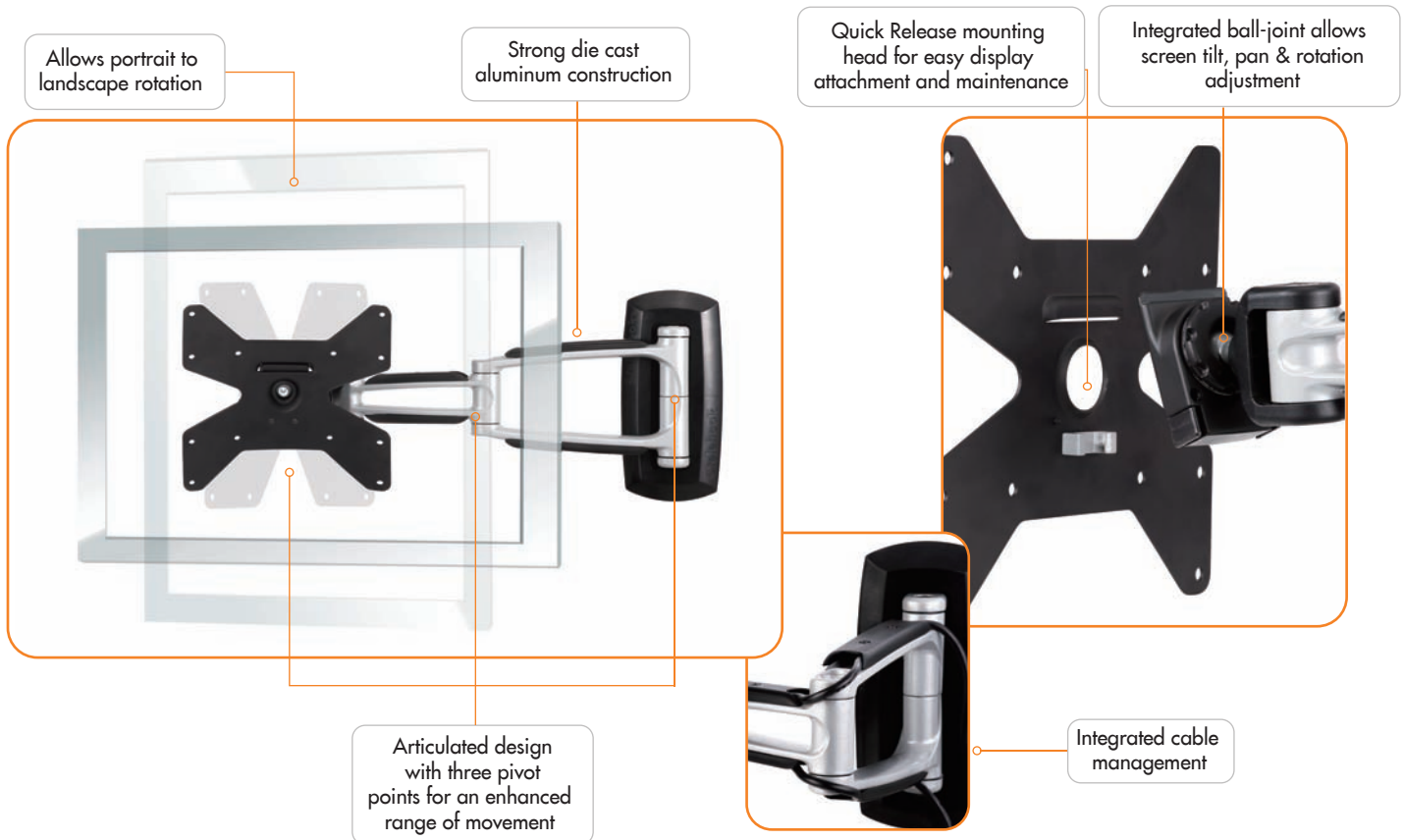

* Supports 75x75, 100x100, 200x100 & 200mmx200mm VESA hole patterns. Also supports 200x300, 200x400, 300x200, 300x300, 300x400, 400x200, 400x300 & 400mmx400mm via optional adaptor accessory

Product information, single unit

Model code	Load capacity	Material	Color
TH-1040-VFM	25kg (55lbs)	Die cast aluminium arm, steel wall plate & display bracket, plastic trim	Matt silver with black trim

Package information, single unit

Size	Ship weight	UPC code	Contents
32mm x 26.5mm x 15mm (12.5" x 10.5" x 6")	3.2kg (7.2lbs)	881493004702	Mount (pre-assembled) with wall cover, security screw, install guide, display and attachment hardware

Package information, master pack

Size	Ship weight	UPC	Units per master pack
64mm x 35mm x 29mm (13.5" x 11.25" x 25")	14kg (30.2lbs)	881493004719	4

Technical drawings

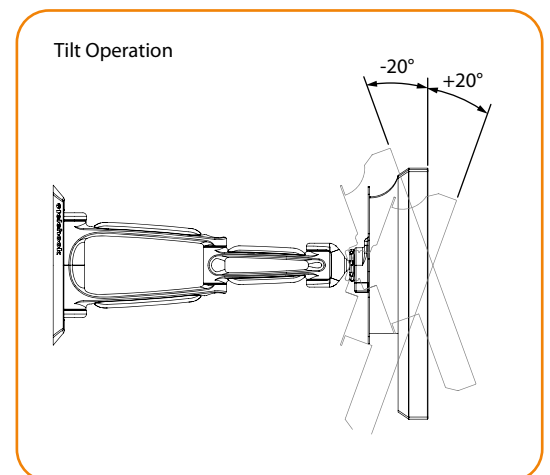
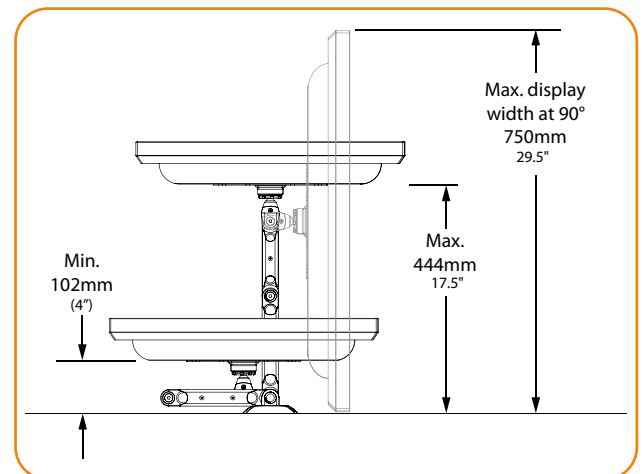
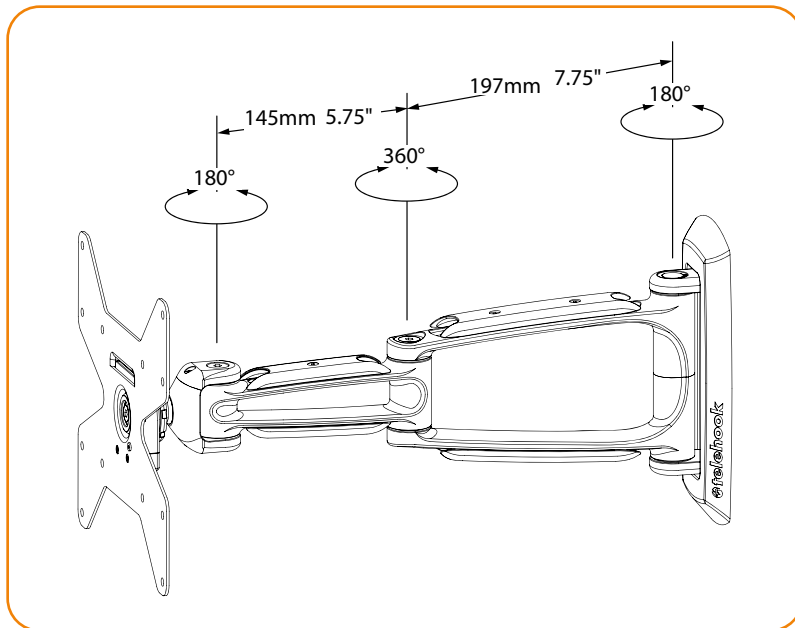

Accessory options

AC-AP-4040	400x400 VESA adaptor
------------	----------------------

Other models in this range

TH-1032-VFM	Low weight Full Motion swing arm
TH-2050-VFM	Medium weight Full Motion articulated arm
TH-3270-UFM	High weight Full Motion articulated arm
TH-3060-SAU	High weight swing arm (silver)