

EN Read the entire instruction manual before you start installation and assembly. If you have any questions regarding any of the instructions or warnings, please contact your local distributor for assistance.

CAUTION: Use with products heavier than the rated weights indicated may result in instability causing possible injury.

- Please closely follow the assembly instructions. Improper installation may result in damage or serious personal injury.
- Safety gear and proper tools must be used. This product should only be installed by professionals.
- This product is designed to be installed on solid concrete walls, masonry walls or wood stud walls.
- Make sure that the supporting surface will safely support the combined weight of the equipment and all attached hardware and components.
- Use the mounting screws provided and DO NOT OVER TIGHTEN mounting screws.
- This product contains small items that could be a choking hazard if swallowed. Keep these items away from children.
- This product is intended for indoor use only. Using this product outdoors could lead to product failure and personal injury.

IMPORTANT: Ensure that you have received all parts according to the component checklist prior to installation. If any parts are missing or faulty, contact your place of purchase for a replacement.

MAINTENANCE: Check that the product is secure and safe to use at regular intervals (at least every three months).

H 8126C

DYNALINK

Instruction Manual

FULL-MOTION TV WALL MOUNT

Dynalink Distributors warrants this product for one year from date of purchase from Dynalink or its resellers to the consumer. If this item is part of an installation or another product, please contact the installer or supplier for your warranty.

During the warranty period, we undertake to repair or replace your product at no charge if found to be defective due to a manufacturing fault. The warranty excludes damage by misuse or incorrect installation

(i.e. failure to install and operate device according to specifications in the supplied instruction manual), neglect, shipping accident, or no fault found, nor by use in a way or manner not intended by the supplier

For repair or service please contact your PLACE OF PURCHASE.

If this item was purchased directly from Dynalink please make a warranty claim by:

1. FOR MAIL ORDER CUSTOMERS (includes school and trade orders),

a) Calling your nearest store location and quoting your tax invoice number.

b) Upon contacting Dynalink, we will issue an R.A. (Return Authorisation). As Dynalink have a number of service agents throughout Australia, a copy of the R.A. will be emailed, faxed or mailed to you with full instructions of how and where to send the goods. The freight for shipping goods back to Dynalink for all repairs is at the customers expense.

c) A copy of the R.A. form, (or at the very minimum, the R.A. number) must accompany the goods to effect the repair.

d) Dynalink will pay the return freight to the customer where the warranty claim has been accepted.

e) Please quote the R.A. number in any correspondence to us.

2. FOR OVER THE COUNTER PURCHASES to make a warranty claim, please return the goods to us in any of our stores, with a copy of your proof of purchase (tax invoice).

a) Upon leaving the goods at one of our stores, an R.A. number will be issued to you.

b) Once repaired, you will be contacted, advising that the goods are ready to be collected from the store

. It is at Dynalink discretion as to whether the goods will be repaired or replaced (whilst under warranty); and as to whether identical goods will be used to replace the item due to changes of models / products.

Note: Under no circumstances should you attempt to repair the device yourself or via a non-authorized Dynalink service centre, as this will invalidate the warranty!

Our goods come with guarantees that cannot be excluded under the Australian Consumer Law. You are entitled to a replacement or refund for a major failure and for compensation for any other reasonably foreseeable loss or damage. You are also entitled to have the goods repaired or replaced if the goods fail to be of acceptable quality and the failure does not amount to a major failure.

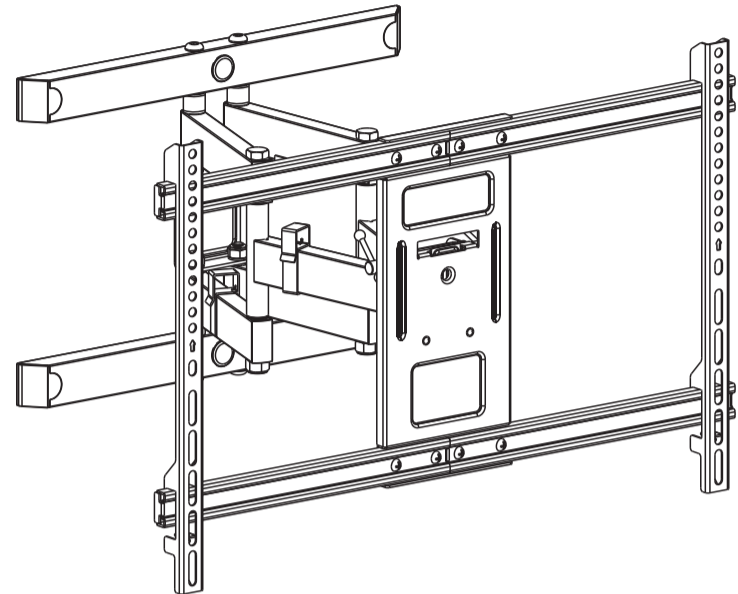

H 8126C

VESA Compatible
300x200 300x300 400x200
400x300 400x400
600x400 800x400

90"
MAX

60kg
(132lbs)
RATED

Revision 16/10/2020

5

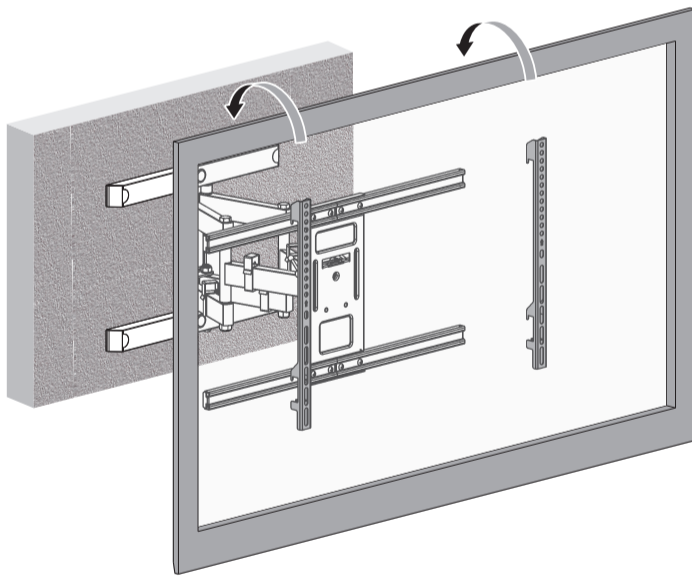

6

