



Professional Four Zone Desktop Mixing Amplifiers

A 4324 240W



Operating Instructions

JDM® 4 Zone Public Address Amplifier

Congratulations on purchasing this 4-Zone amplifier. It is housed in a heavy duty 3RU rack mount cabinet and includes a host of features. It provides an economical solution for smaller installations including offices, workshops, smaller shopping arcades, schools etc.

FEATURES

VERSATILE INPUTS

Channels 1 - 5 are combination XLR / 6.35mm balanced jack sockets located on the rear panel. The XLR are microphone level and the 6.35mm are line level (tip / ring / sleeve) inputs.

TELEPHONE INPUT

A telephone paging and music-on-hold input connection is provided via spring terminals on the rear panel. Music sources can be from a choice of optional modules that are installed into the front panel slot.

SLOT FOR OPTIONAL INPUT MODULES

A slot in the front panel is provided in order to fit one of the following optional modules: A 4344A (TP-100RDS) AM/FM RDS Radio tuner module, A 4346 (CDR-100RDSU) CD/tuner module with USB.

PRIORITY MUTING

MIC 1, CHIME and SIREN have priority over other inputs. The muting level can be adjusted via a knob on rear panel.

REMOTE CHIME AND SIREN

This is operated by buttons on the front panel which play various tones across the speakers. When the spring terminal on the rear panel is shorted, CHIME is activated.

FOUR ZONES SPEAKER SELECTOR

Any combination of mono speakers (4 or 8ohm) can be selected via front panel selector switches.

PRE OUT

A preamp output socket is provided enabling connection to extra slave amplifiers or a signal processor.

24V EMERGENCY OPERATION

The unit will operate from 24V batteries for use in emergency applications. Screw terminals provided on the rear.

AMP SECTION

- Automatic variable speed fan
- Over current protection
- Load short circuit protection
- Built-in low pass filter circuit
- Output level LED VU meter

SAFETY INSTRUCTIONS

- Please read these instructions before use. DO NOT switch on the mains power until installation is complete.
- Locate the device away from any heat source, such as radiators, heating vents or in direct sunlight etc.
- DO NOT install in a confined space such as a cupboard or book case. Ensure adequate ventilation of the unit.
- DO NOT expose to any form of liquid.
- DO NOT drop any foreign object or liquid inside the amplifier.
- This device should be serviced by a qualified service person.

IN THE BOX

- JD-Media PA Mixer Console
- Power Cord
- Rack Mounting Screws and Washers
- Operation Manual

OPTIONAL ACCESSORIES

- A 4346 CD Player / AM/FM Radio Tuner module (CDR-100RDSU) with FM RDS / USB
- A 4344A– AM/FM Radio Tuner module (TP-100RDS) with FM RDS

Note: The two modules listed above fit into the slot on the PA mixer front panel. Each module includes the antenna terminal, which fits into the PA amplifier rear panel.

- C 0377 - PUSH-TO-TALK Paging Mic which connects using only a 3-Pin XLR Jack.

Note: These are the accessories which are supported for this product in Australia, and which have descriptions within this manual, as well as having their own manuals.

INSTALLATION

MOUNTING:

These amplifiers are designed to fit into standard 19" racking space, and include the left and right mounting brackets in the box.

COOLING:

When installing in a rack frame, never block the air vents on the side, and make sure there is enough space (44mm) on either side of the amplifier to allow air flow. Check the temperature inside the rack system to ensure it is not above 40 degrees Celsius. A cooling fan on the rear rack panel is recommended.

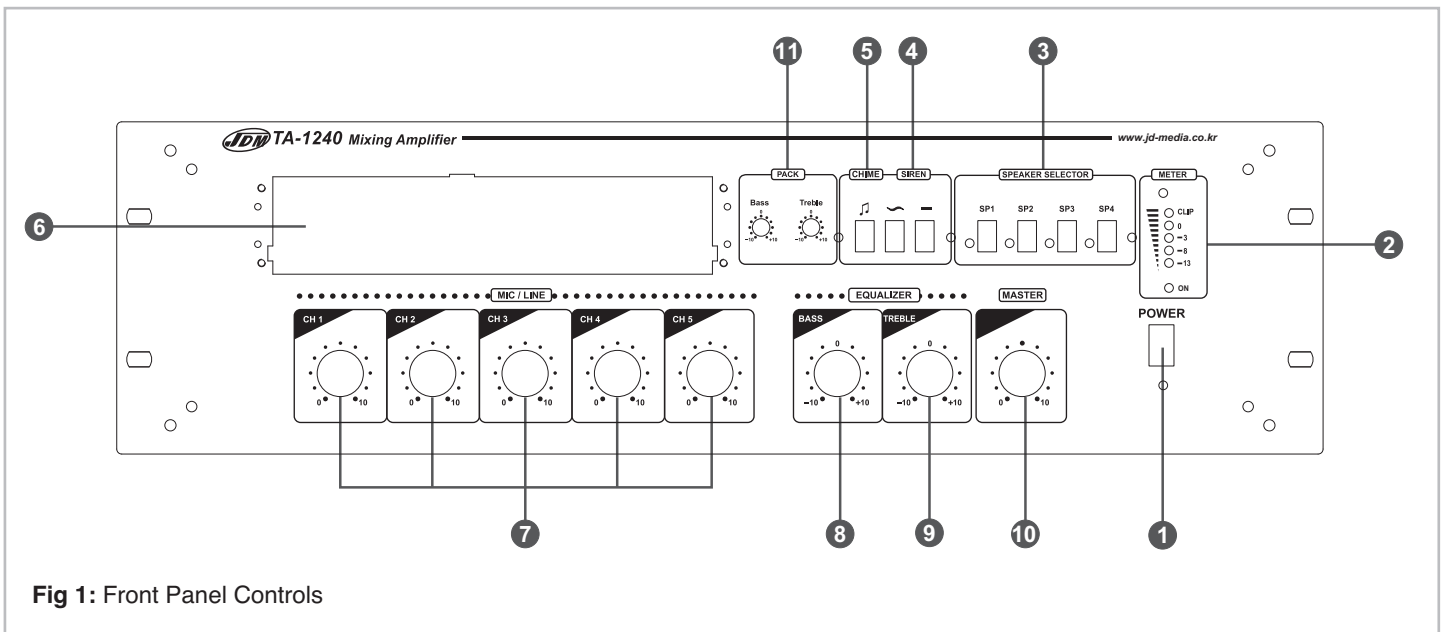

Fig 1: Front Panel Controls

FRONT PANEL CONTROLS

1. POWER

Push switch to turn on. Power LED will illuminate when on.

2. METER

LEDs display the audio output level on the VU meter.

3. SPEAKER SELECTOR (SP1 – SP4)

These switches activate the amplifier speaker zones. Any zones can be set to any output loading, but the total output loading must not exceed the amplifiers maximum loading specification.

4. SIREN

Pressing these switches will activate the siren tones. Two sound patterns are offered, depending on which button is pressed. One tone is continuous; the other tone varies in pitch in a repeating cycle.

5. CHIME

Pressing this switch will activate the tone chime circuitry. This is a four-tone ascending sound - 'BONG BONG BONG BONG'.

6. BLANK PANEL (PACK)

This is used for mounting the optional tuner (A4344A) or CD player (A4346) modules or 'PACKs', which can be installed into front panel slot, with the complementary antenna module being installed on the rear.

7. MIC / LINE

These knobs (CH 1 to CH 5) adjust the volume levels of the microphone or line inputs as selected by the rear panel switch of CH 1 to CH 5.

8. BASS (EQUALISER)

Knob to adjust the low frequency sound to the MASTER volume output.

9. TREBLE (EQUALISER)

Knob to adjust the high frequency sound to the MASTER volume output.

10. MASTER

This knob is used for adjusting the volume of the output audio mixed from all five sources.

11. PACK (BASS & TREBLE)

These BASS and TREBLE knobs control the bass and treble signals of the optional tuner or CD player (also called 'PACK'), but only when either is installed in the front slot of the amplifier.

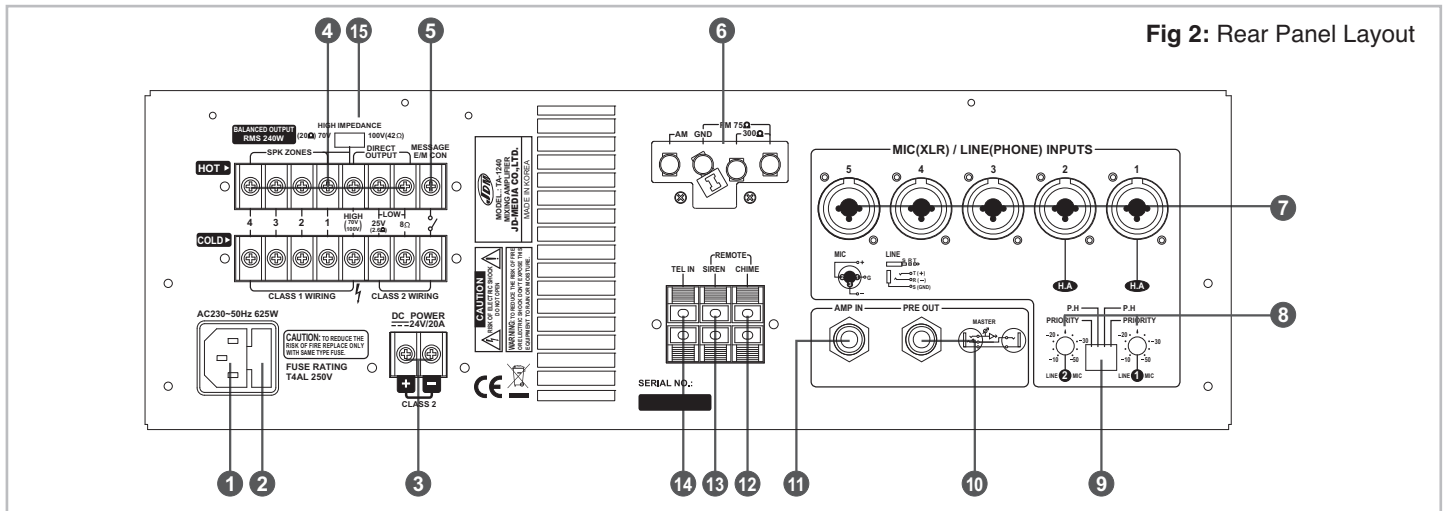

Fig 2: Rear Panel Layout

REAR PANEL CONTROLS

1. AC POWER INPUT.

2. FUSE HOLDER

This fuse holder contains the power fuse (T 4AL 250V). Ensure it is replaced with same type of fuse when it blows. If it continually blows, there may be an amplifier fault. Please contact a qualified service technician.

3. DC POWER 24V/20A

This terminal is for connecting the 24V battery for emergency operations.

WARNING: Ensure the correct battery polarity to prevent damage to the amplifier.

4. SPEAKER ZONES

Refer to the speaker connection terminals figures 3a and 3b.

WARNING:

- Do not connect speakers to more than one terminal type. That is, connect only to the four ohm, or only to the eight ohm, or only to the high impedance terminals.
- Do not connect speakers to the four ohm or eight ohm terminals where the power rating of the speakers is less than the power rating of the amplifier.
- For the high impedance terminals do not connect speakers where the total impedance is less than the rated impedance (see Fig. 3b). Failure to follow this may result in damage to the amplifier and / or speakers.

5. MESSAGE PRIORITY

Not Supported in Australia

6. ANTENNA

Only fitted when either a tuner (A4344A) or CD (A4346) module is installed. See Fig 4 for wiring.

NOTE: The picture of the amplifier's rear panel above shows the antenna terminal in place. This section of the amplifier's rear panel is blocked by a removable 'knock-out' section of metal plate, which needs to be punched out and removed in order for the antenna terminal to be screwed in place.

7. MIC(XLR) / LINE(PHONE) INPUTS

These are for microphone or line inputs CH1 to CH5. Microphone input sensitivity and impedance is 3mV/600 ohm. Line input is 300mV/50k ohms.

The XLR / Phone jack combined sockets have been designed for Mic or Line inputs without the need for switches.

Note: Pin 1 on the XLR and the Sleeve on the phone jack are grounded, as per the diagrams on the rear panel.

8. MUTE

These knobs adjust the muting levels of inputs CH1 and CH2.

9. PRIORITY / (PHANTOM POWER)

Two of the four dip switches provide CH1 and CH2 with phantom power for condenser microphones. The other two switches activate priority muting for the same two channels.

IMPORTANT: When using phantom power, turn the CH1 and CH2 volume control knobs on the front panel anti-clockwise to decrease the level, so as to avoid damaging the speakers.

10. PRE OUT

This jack is for connecting line level output signal to external amplifier or a signal processor such as an equalizer.

11. AMP IN

This input is for a direct signal from external equipment (+4dB level). It is controlled by the MASTER volume knob on the front panel.

12. REMOTE CHIME terminal

When these terminals are shorted, the chime is activated.

13. REMOTE SIREN terminal

When these terminals are shorted, the siren is activated.

14. TEL IN

These terminals are for connection to a telephone system for paging. Use an Austel approved line isolation unit with this input.

Note: When paging, all other input signals except AMP IN are muted.

15. HIGH IMPEDANCE SWITCH

This switch is for selecting the impedance of the high impedance speaker terminals (70V or 100V).

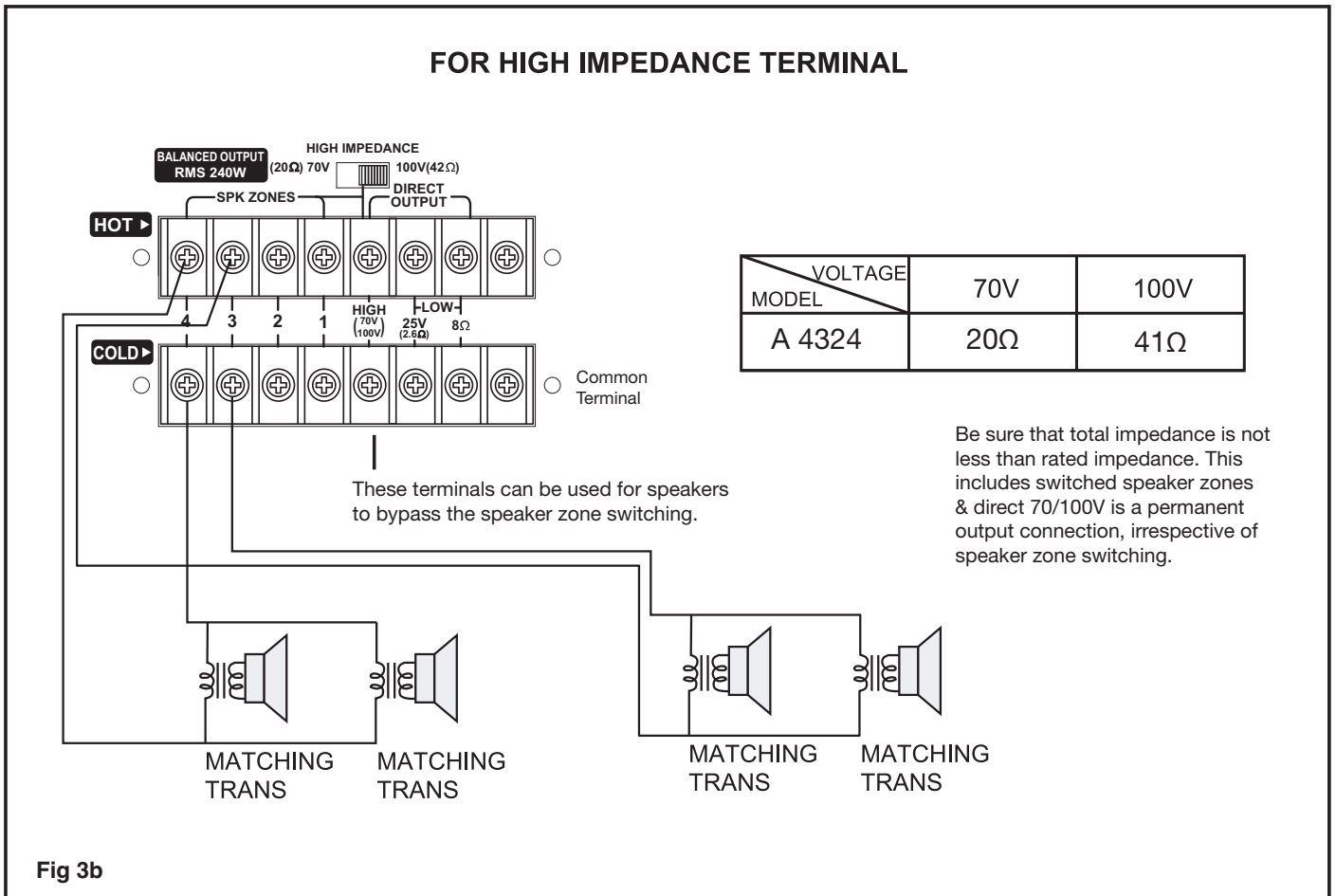
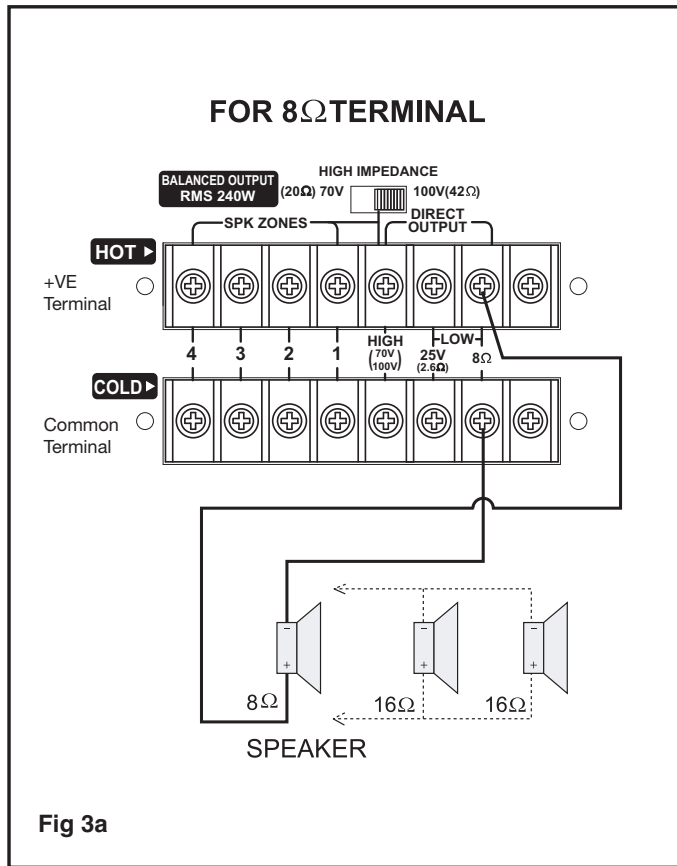

Fig 3a & 3b: Connect speakers as per these diagrams. Ensure power is off before connecting or disconnecting speakers.

JDM® 4 Zone Public Address Amplifier

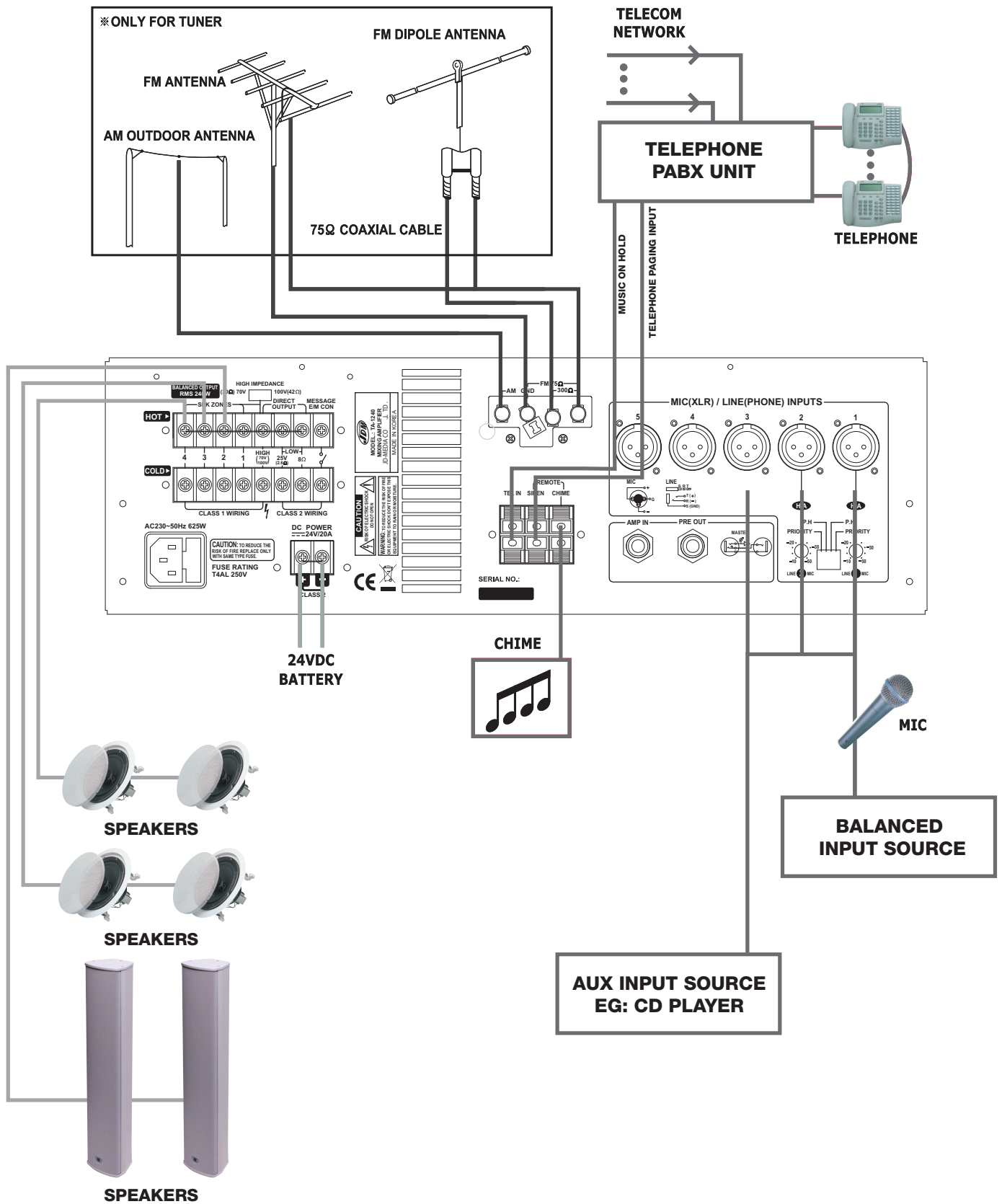

Fig 4: Connection Guide

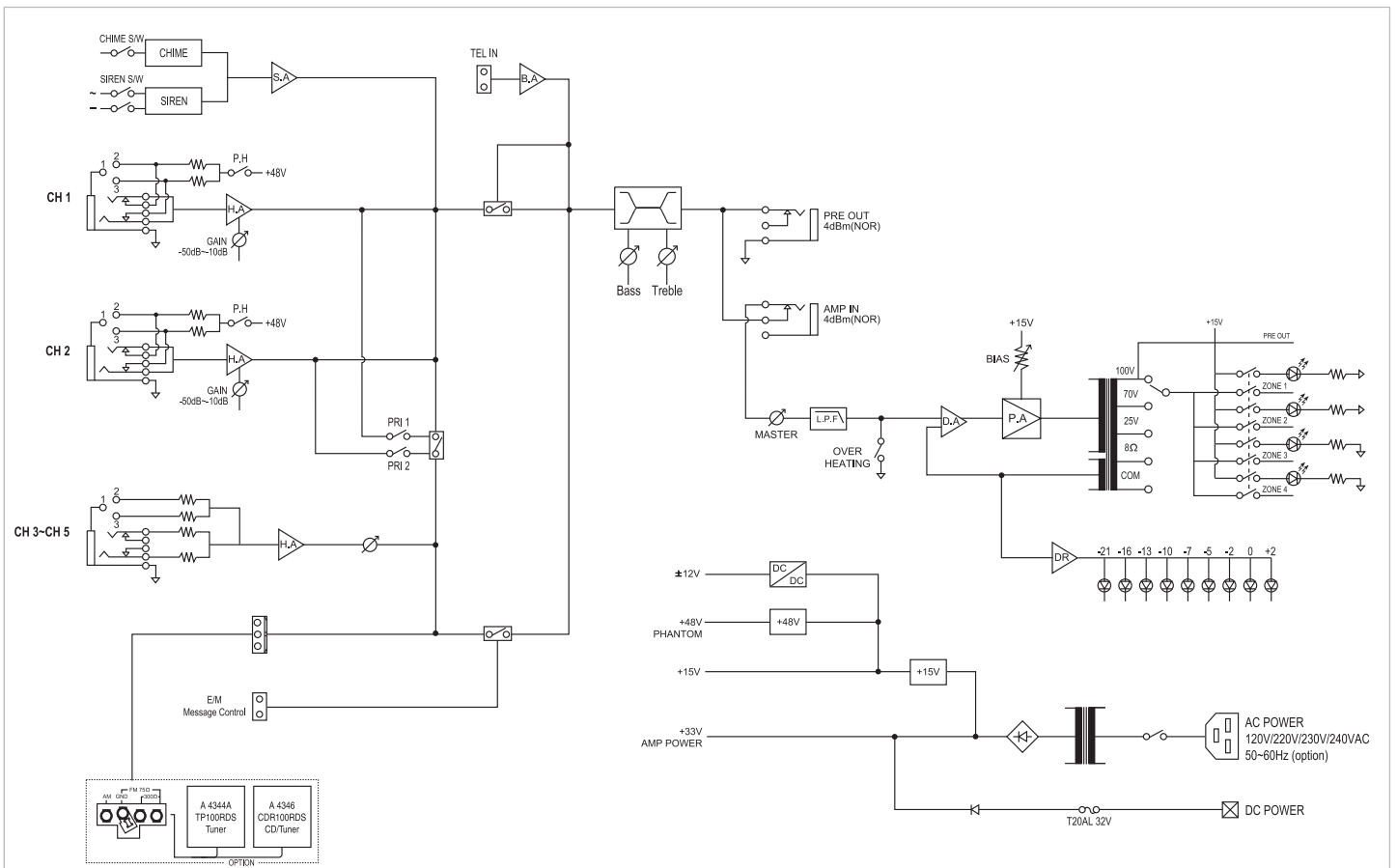

Fig 5: Block circuit diagram.

SPECIFICATIONS

A 4324 power:	240 watts RMS
Distortion:	< 1% @ 1kHz
Signal to noise ratio	Line: >70dB Mic: >60dB
Frequency response	80Hz - 15kHz, ±3dB
Mic input sensitivity:	3mV balanced
Line inputs sensitivity:	300mV
Phono input sensitivity:	2.4mV
Telephone input	245mV
Bass:	±10dB @ 100Hz
Treble:	±10dB @ 10kHz
Standby current (DC operation):	0.51A
Fuse	T4AL 4A M205 4 x 20mm type
Power supply:	240V AC or 24V DC
Dimensions:	≈483W x 350D x 133H mm
A 4324 weight:	18.7kg

JDM® 4 Zone Public Address Amplifier

JDM warrants this product for two years from the date of purchase from its resellers to the consumer. If this item is part of an installation or another product, please contact the installer or supplier for your warranty.

During the warranty period, we undertake to repair or replace your product at no charge if found to be defective due to a manufacturing fault. The warranty excludes damage by misuse or incorrect installation (i.e. failure to install and operate device according to specifications in the supplied instruction manual), neglect, shipping accident, or no fault found, nor by use in a way or manner not intended by the supplier.

For repair or service please contact your PLACE OF PURCHASE.

Note: Under no circumstances should you attempt to repair the device yourself or via a non-authorized JDM service centre, as this will invalidate the warranty!

Our goods come with guarantees that cannot be excluded under the Australian Consumer Law. You are entitled to a replacement or refund for a major failure and for compensation for any other reasonably foreseeable loss or damage. You are also entitled to have the goods repaired or replaced if the goods fail to be of acceptable quality and the failure does not amount to a major failure.