

# QMW101 Installation guide

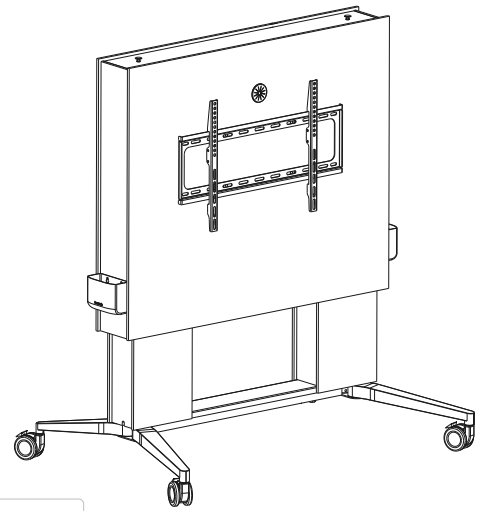

### Technical data

Maximum load capacity	90kg
Height Range	1080-1820mm
Suitable TV Sizes	32"-86"

### Accessory list

Attention: The drawings below are only for reference and might be slightly different from the actual object. For any tools missing or installation problems, please contact customer service.

No.	Image	Spec	Qty
A		M4x12mm	2
B		M6x25mm	4
C		M8x25mm	4
D		M8x16&M8X36	4+4
E		Rectangular Washer	4
F		Magnetic Level	1
G		Washer	4
H		Spacer	4+4

### Component list

1. Product: Motorised Trolley / Media Wall (x1)
2. Top cover (x1)
3. Storage box (x2)
4. TV bracket (x1)
5. TV bracket arms (x2)
6. Rotary Knob (x2)

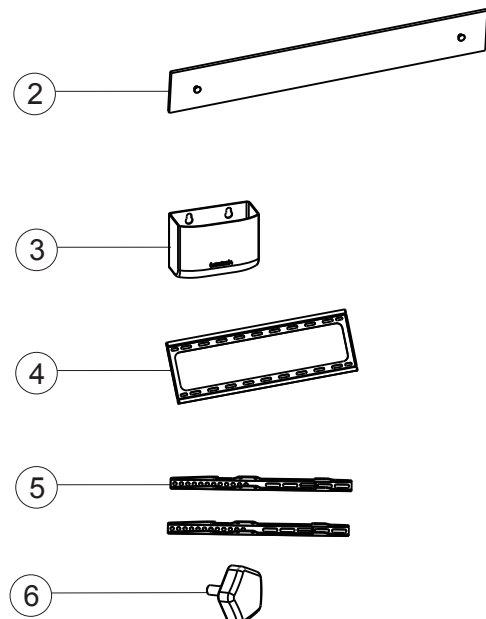
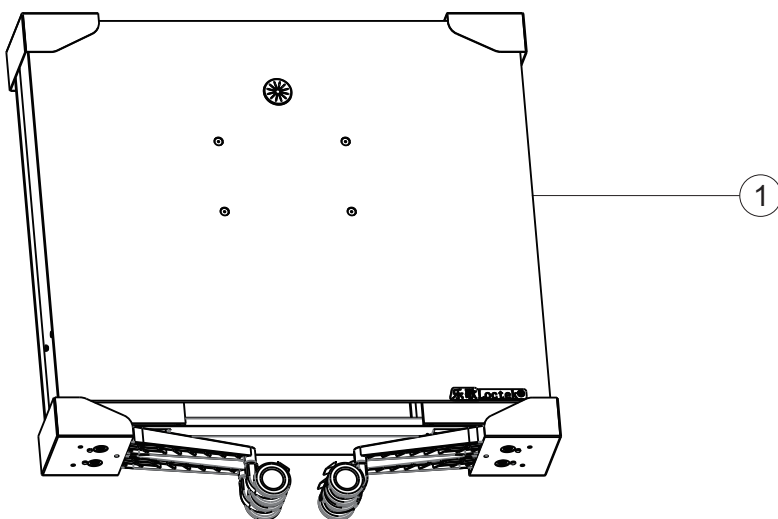

### STEP 1

Remove the corner guards on both sides of the foot of packaging.

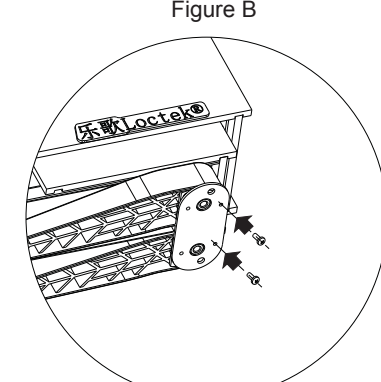
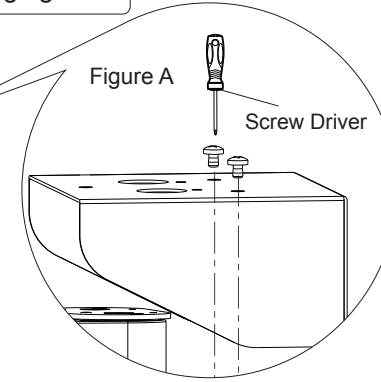
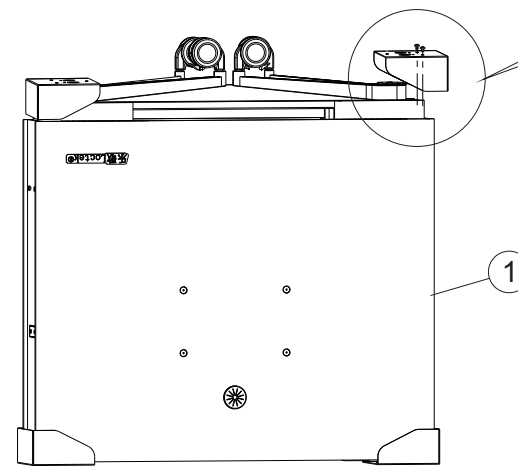

Put the product up side down. Remove the corner guards on both sides of the bottom foot of the product with a screwdriver (figure A). Then install the screw on the bottom foot on the threaded hole of sheet metal (figure B).

### STEP 2

Open up the legs

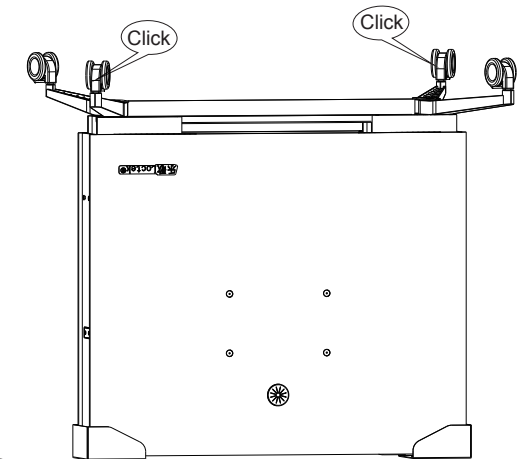
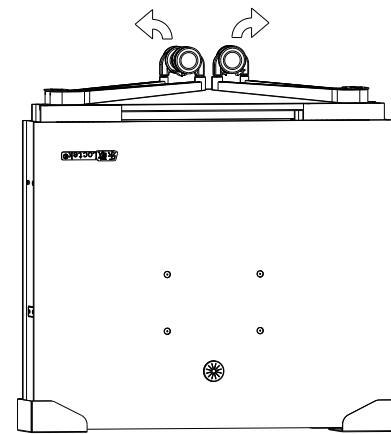

Open up the legs according to the directions shown on the picture, and when you hear "click" the foot setting is finished.

### STEP 3

Remove top metal plate and then install top covers

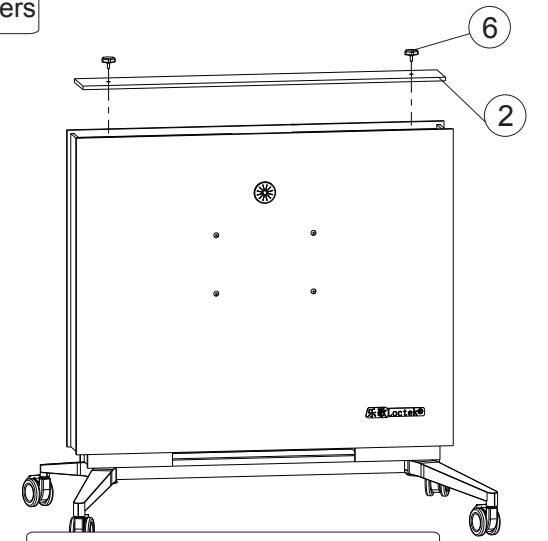
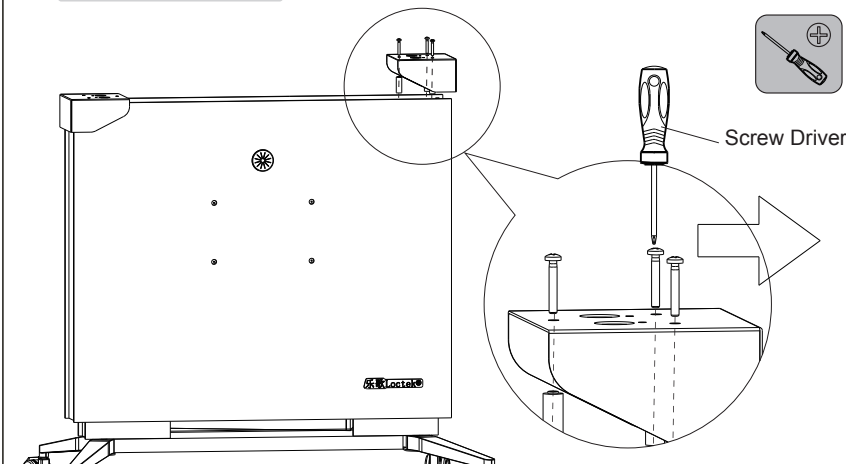

Use a screwdriver to remove the corners on both sides of the product. The removed parts are no longer required.

Install top shield plate with rotary knob.

### STEP 4

Remove office plug and install storage box.

Firstly, install the storage box on the axle, then press it down slightly.

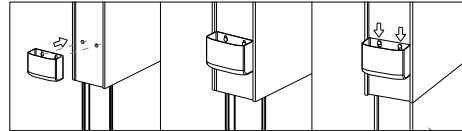

Control Panel

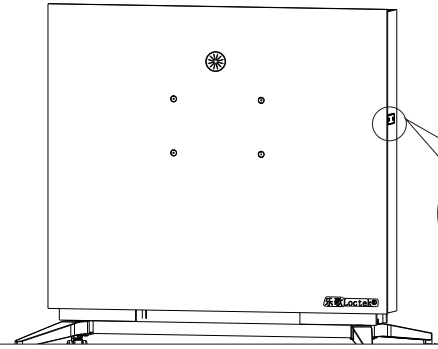

After connecting the product's power plug to an external power source, raise the product to the appropriate height with the control panel. Then remove the four holes on the front panel by hand-tightening the screws (A). Remove the storage box from the package and secure it to the left and right sides of the product through the reserved hanging shaft as shown.

A x2

First attach the thumb screw (A) to the threaded hole of the plug and then pull it together.

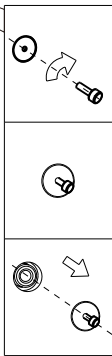

### STEP 7

Connecting cables

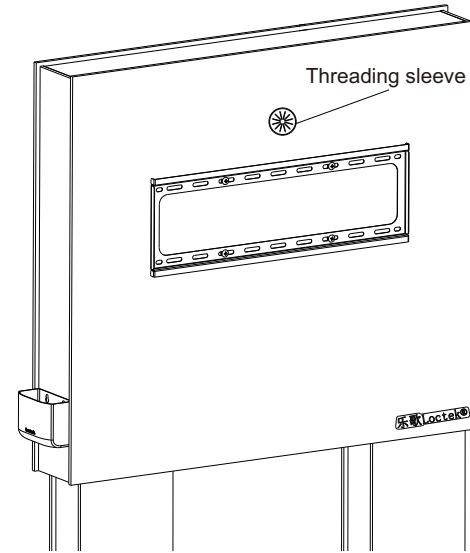

Threading sleeve

Power cord

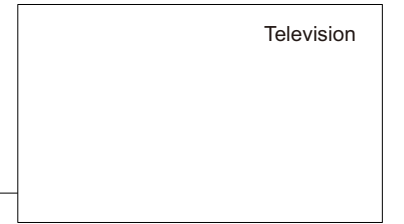

Television

Insert the power cord of the TV into the threading sleeve

### STEP 5

Install TV bracket

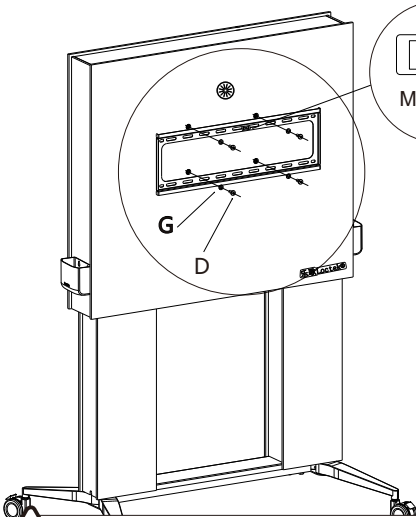

Magnetic Level

Magnetic Level

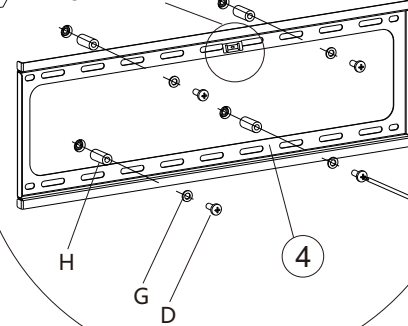

D x4  
G x4  
H x4

Screwdriver

Use a screwdriver to attach the screws (D), washers (G), spacers (H) and TV bracket to the threaded holes on the front panel of the product. Use the magnetic level (F) to calibrate whether the TV bracket is installed level.

**Attention:** If you do not need to install the TV, please ignore next steps.

### STEP 8

Hanging the TV

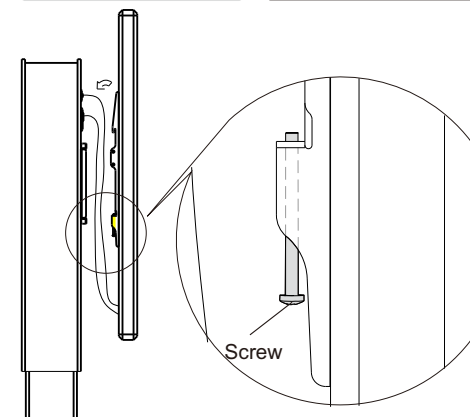

Screw

Power outlet  
(located on the inside  
of the product)

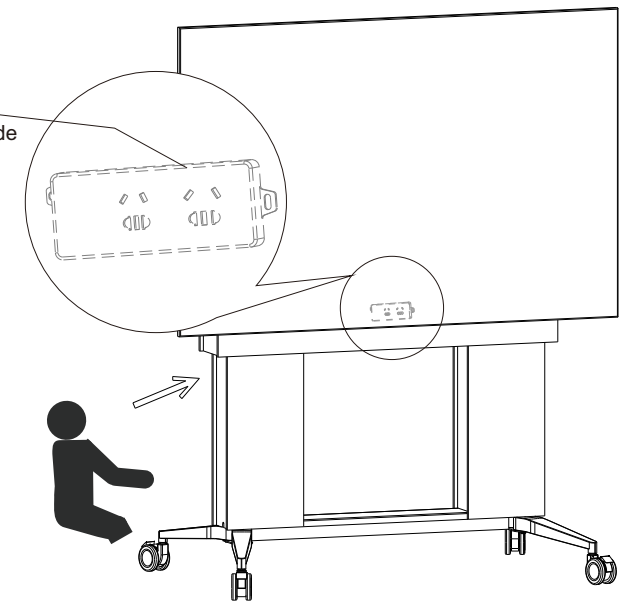

Install the TV on the TV bracket and tighten the screws with a screwdriver, then plug the TV's power cord into the power strip inside the product.

### STEP 6

Connect the TV to the TV bracket arms

B x4 C x4 E x4 H x4

Rectangular washer (E)

Used for M8 screw

Used for M6 screw

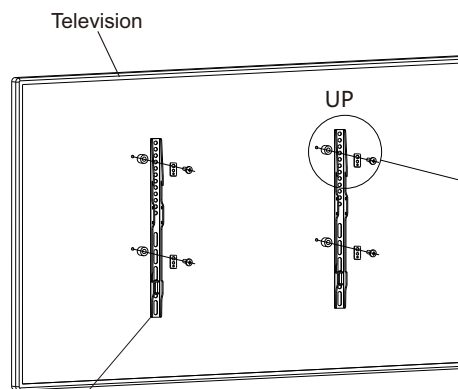

5

Use a screwdriver to attach the screws (B) or screws (C), rectangular washer (E), TV bracket arms and spacers (H) to the TV

### Common fault treatment

The following tips will help you detect and fix common errors made when using the product. If you need further assistance, please contact your supplier.

Fault phenomenon	Method
No response after pressing the down arrow while connected to a power supply for a long period of time.	1. Check if all the cables are connected firmly 2. Contact your supplier or dealer
No response while pressing up arrow/ down arrow after connected with a power supply	1. Check if all the cables are connected firmly 2. Contact your supplier or dealer
Rises in a low speed	1. Check if overloaded, max loading: 90kg; 2. Contact your supplier or dealer
The motor does not move as instructed	1. Contact your supplier or dealer
Goes down but not up	1. Reposition 2. Contact your supplier or dealer
Slides downwards	1. Check if overloaded, max loading: 90kg; 2. Contact your supplier or dealer
Frequently re-positions	1. Check if overloaded, max loading: 90kg; 2. Contact your supplier or dealer
<b>Overwork</b> (Duty cycle: Max 2min on/18min OFF)	1. Restart after suspend for 18mins while connecting with power; 2. Contact your supplier or dealer;



### Attention

1. Power supply: AC100V-240V,50/60Hz
2. Service Environment: 0-40°C
3. Unplug the power plug before cleaning, wipe the dust off surface with slightly wet dishcloth, be careful not to let the drops into internal parts, don't lose the connector.
4. The electric box contains electronic components, metals, plastics, wires etc., so dispose of it in accordance with each country's environmental legislation, not the general household waste.
5. Check carefully to ensure correct and complete assembly before using.
6. Be familiar with all functions and program settings of the product before first use.
7. Children are forbidden to play on the product due to possible injury.
8. Slight noise caused by the V-ribbed belt or brake system due to structure will not have any effect on the use of the equipment.
9. Corrosive or abrasive materials are forbidden to clean the equipment. Must ensure that the cleaner used will not pollute the environment.
10. This appliance can be used by children aged from 8 years and above and persons with reduced physical, sensory or mental capabilities or lack of experience and knowledge if they have been given supervision or instruction concerning use of the appliance in a safe way and understand the hazards involved. Children shall not play with the appliance.
11. Cleaning and user maintenance shall not be made by children without supervision.
12. If the supply cord is damaged, it must be replaced by the manufacturer, its service agent or a similarly qualified person in order to avoid a hazard.
13. Please make sure there is no hazard sources in your operating environment e.g. do not litter tools. Always be careful to treat the packaging materials with care in order to avoid any possible danger e.g. plastic bag may lead to choking hazard for children.
14. Keep the original package of the equipment if necessary in case of the future use in transportation.
15. Make sure you have read the instructions before installation and fully understand how to install them. If you do not understand any of the installation steps, please contact the professional installer.
16. Keep the original package of the equipment if necessary for future use in transportation.
17. Please check the connecting parts every two months to check if the screws are loose.
18. Before installation, please make sure to check the load capacity. Never exceed the maximum load of 100Kg (the weight of the TV bracket does not exceed 100Kg), otherwise it will cause damage to the product or personal injury.
19. Note: These products are for indoor use only. If used outdoors, it may cause damage to the product or personal injury.

### Waste disposal



This marking indicates that this product should not be disposed with other household wastes. To prevent possible harm to the environment or human health from uncontrolled waste disposal, recycle it responsibly to promote the sustainable reuse of material resources. To return your used device, please use the return and collection systems or contact the retailer where the product was purchased. They can take this product for environmental safe recycling.