

8. Cable Management

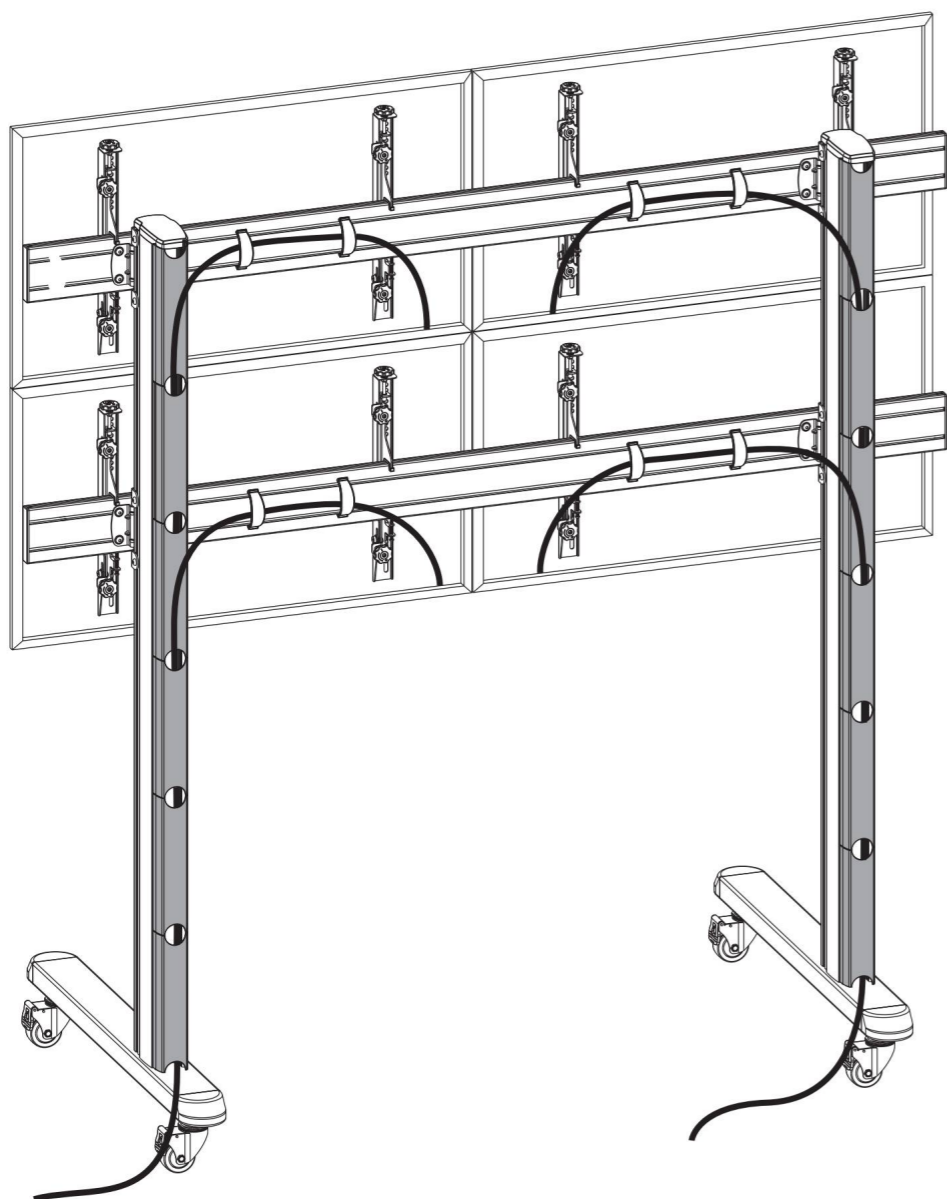
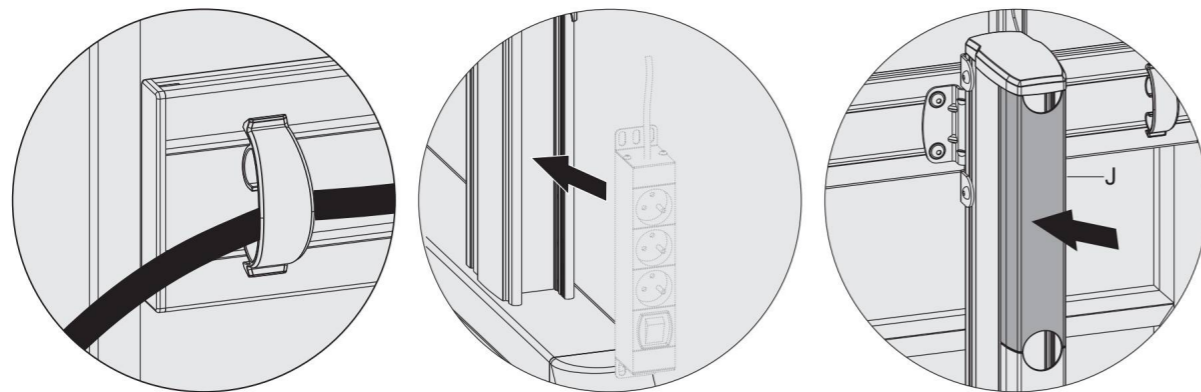

Maintenance

- Check that the bracket is secure and safe to use at regular intervals(at least every three months).
- Please contact your distributor if you have any questions.

Video Wall Cart

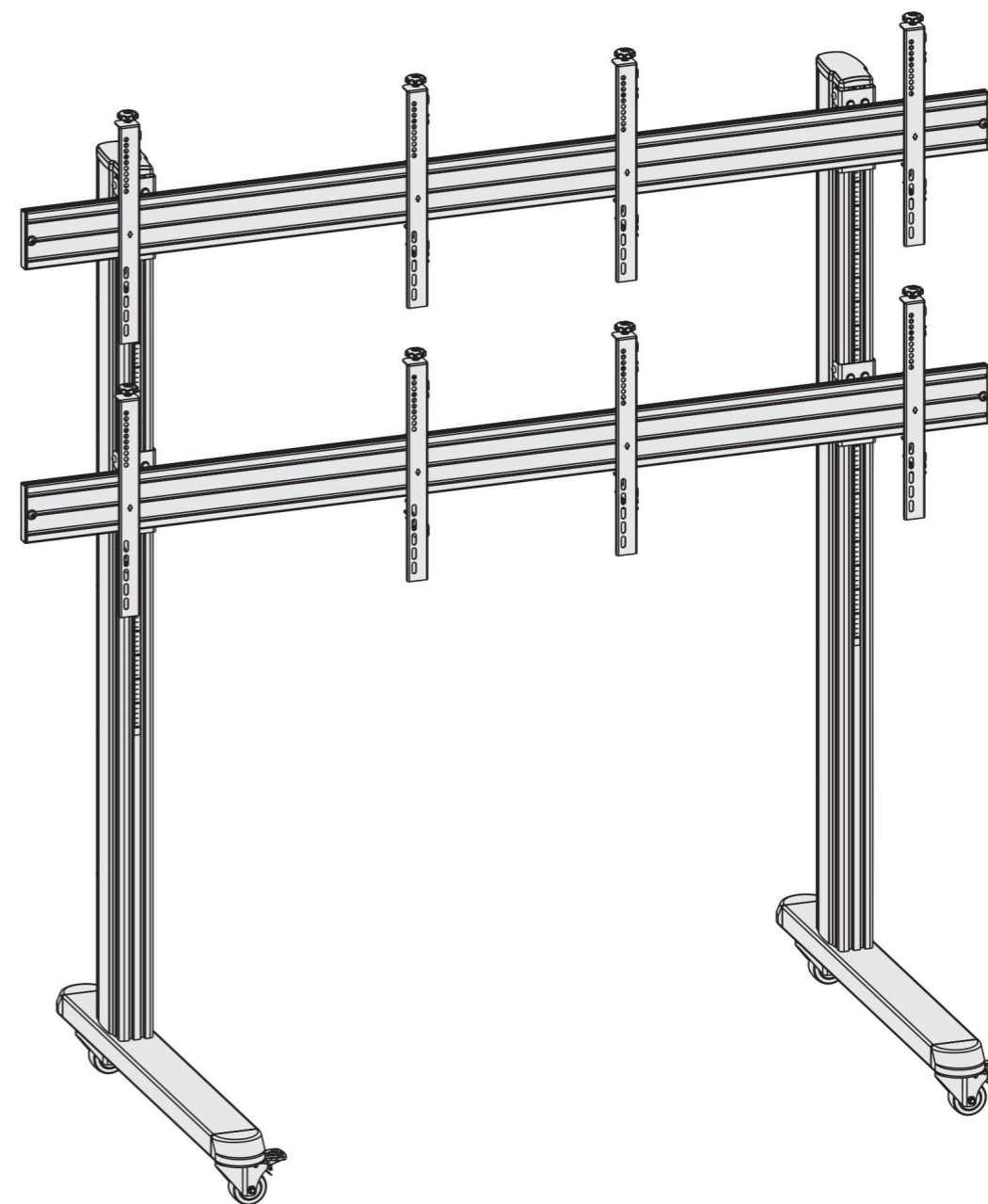

INSTALLATION MANUAL

QVS02446FW



200x200/300x300
400x200/400x400
600x400



50kgx4/110lbsx4

NOTE: Read the entire instruction manual before you start installation and assembly.

⚠ WARNING

- Do not begin the installation until you have read and understood all the instructions and warnings contained in this installation sheet. If you have any questions regarding any of the instructions or warnings, please contact your local distributor.
- This mounting bracket was designed to be installed and utilised **ONLY** as specified in this manual. Improper installation of this product may cause damage or serious injury.
- This product should only be installed by someone with good mechanical ability who has basic building experience and fully understands this manual.
- Make sure that the supporting surface will safely support the combined weight of the equipment and all attached hardware and components.
- Always use an assistant or mechanical lifting equipment to safely lift and position the equipment.
- Tighten screws firmly, but do not over tighten. Over tightening can cause damage to the items, This greatly reduces their holding power.
- This product is intended for indoor use only. Using this product outdoors could lead to product failure and personal injury.

Required for Installation



Component Checklist

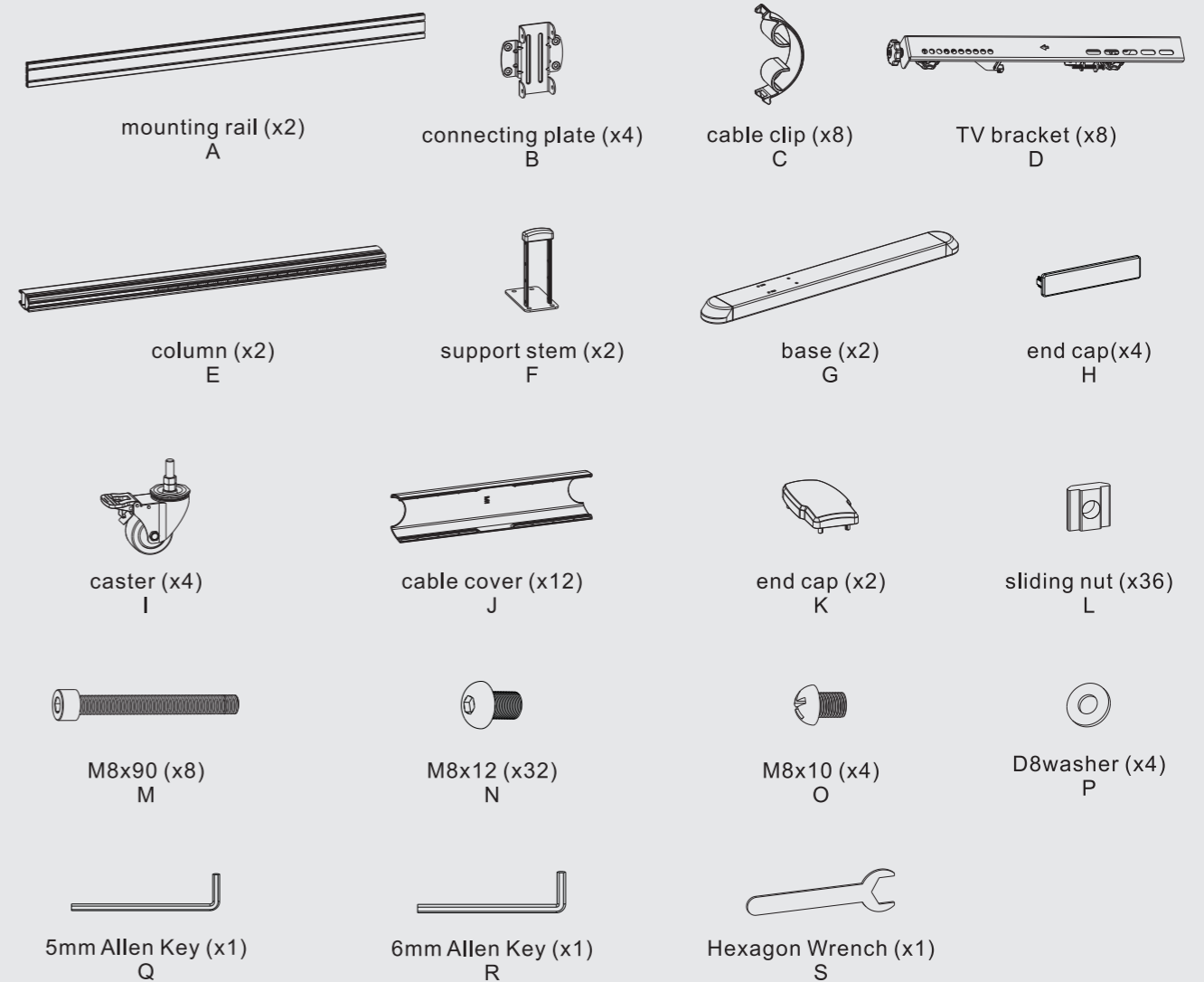

IMPORTANT: Ensure that you have received all parts according to the component checklist prior to installation. If any parts are missing or faulty, contact your place of purchase for a replacement.

Package Mx4

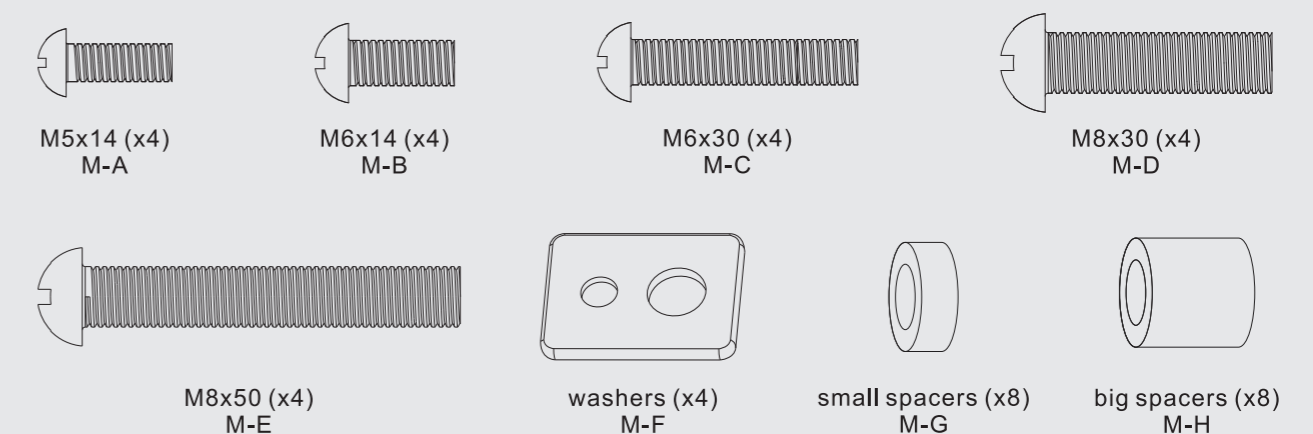

1. Attach Connecting Plate to the Column

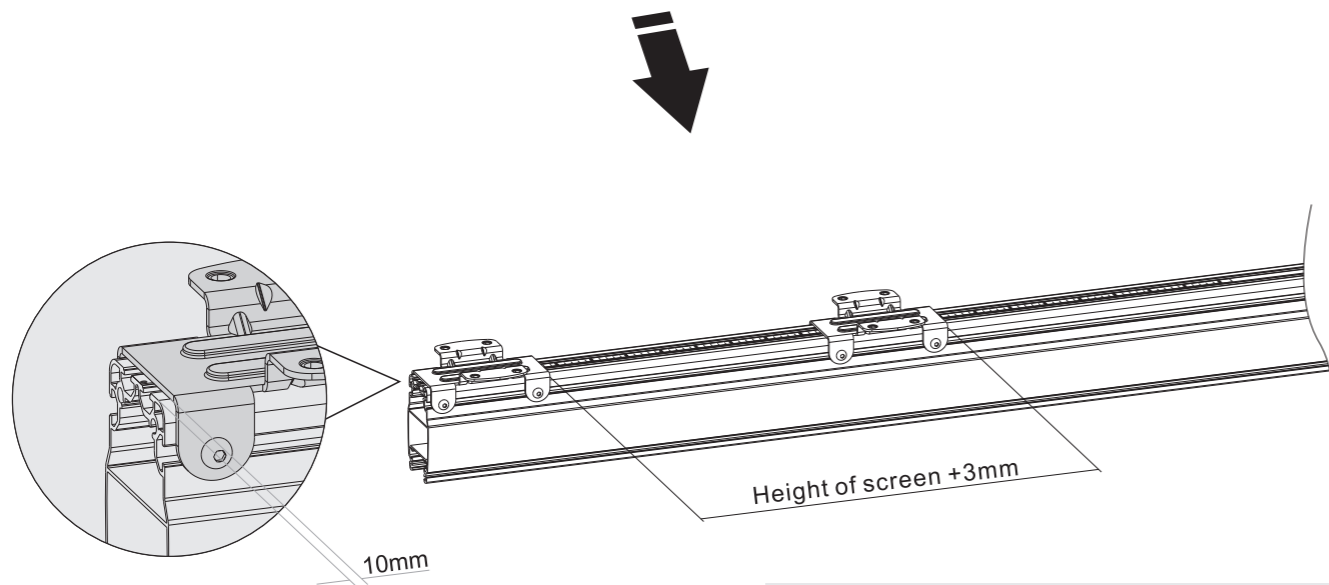
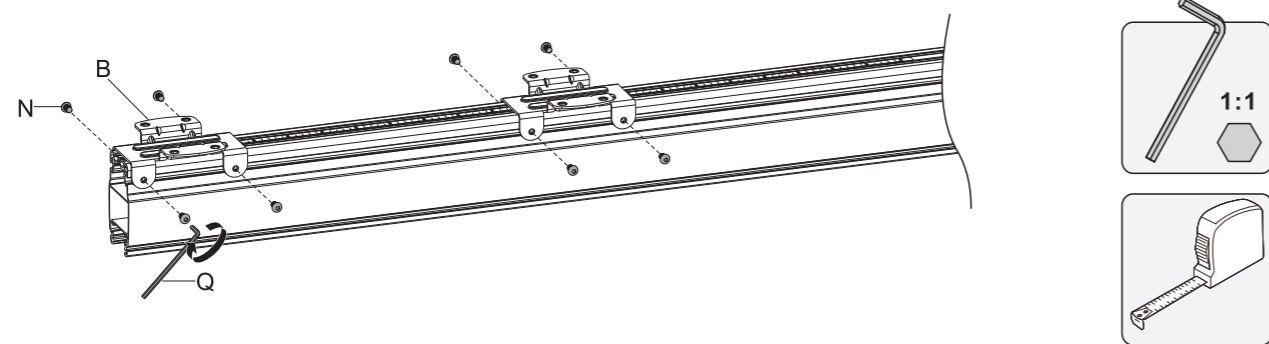
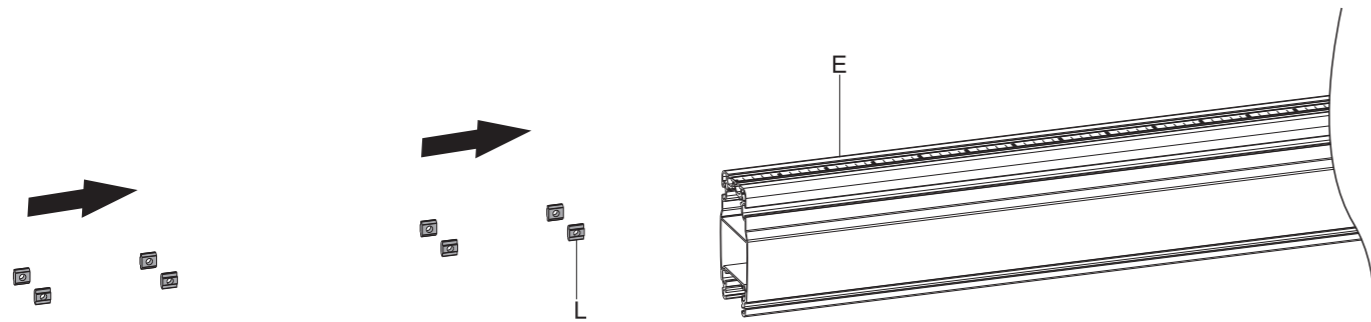

Note: The space apart the connect plates is the height of the screen plus and extra 3 mm.

2. Attach Column to the Mounting Rail

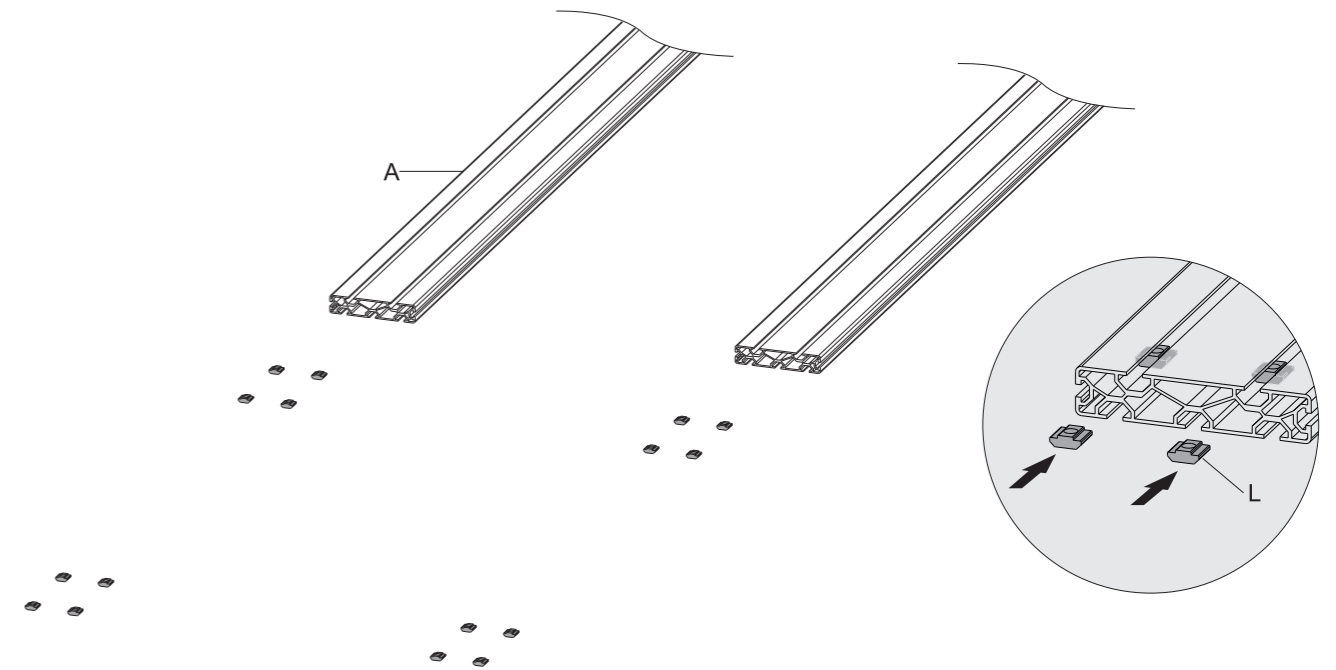

Note: Ensure the gap between the nuts halves on both sides are equal.

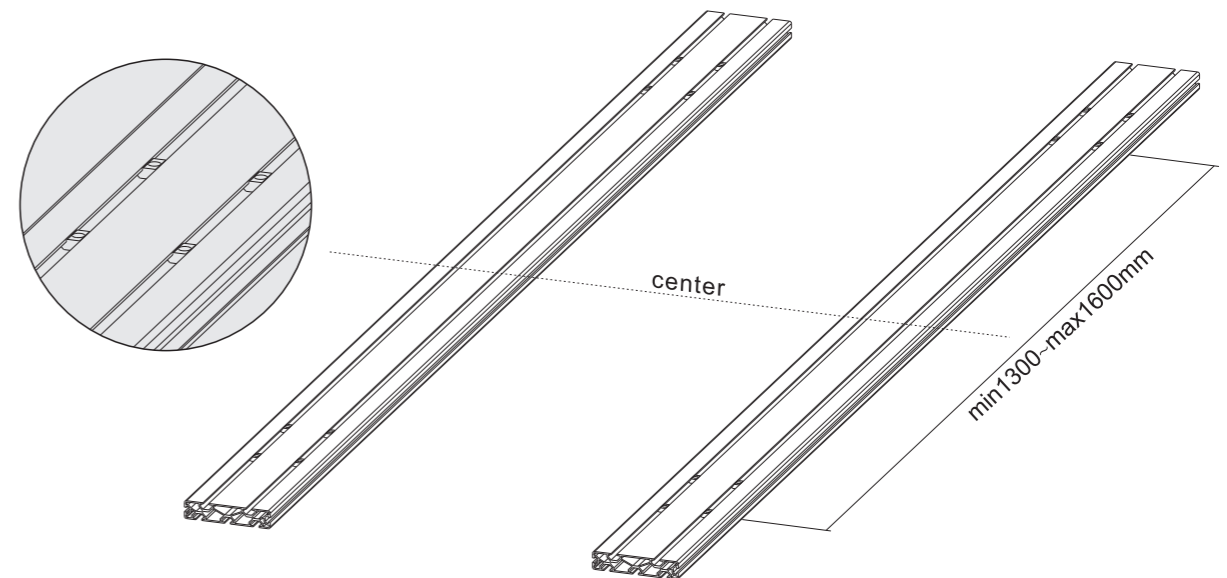

Note: Make sure the position of mounting rails are parallel before any AV equipment is fitted.

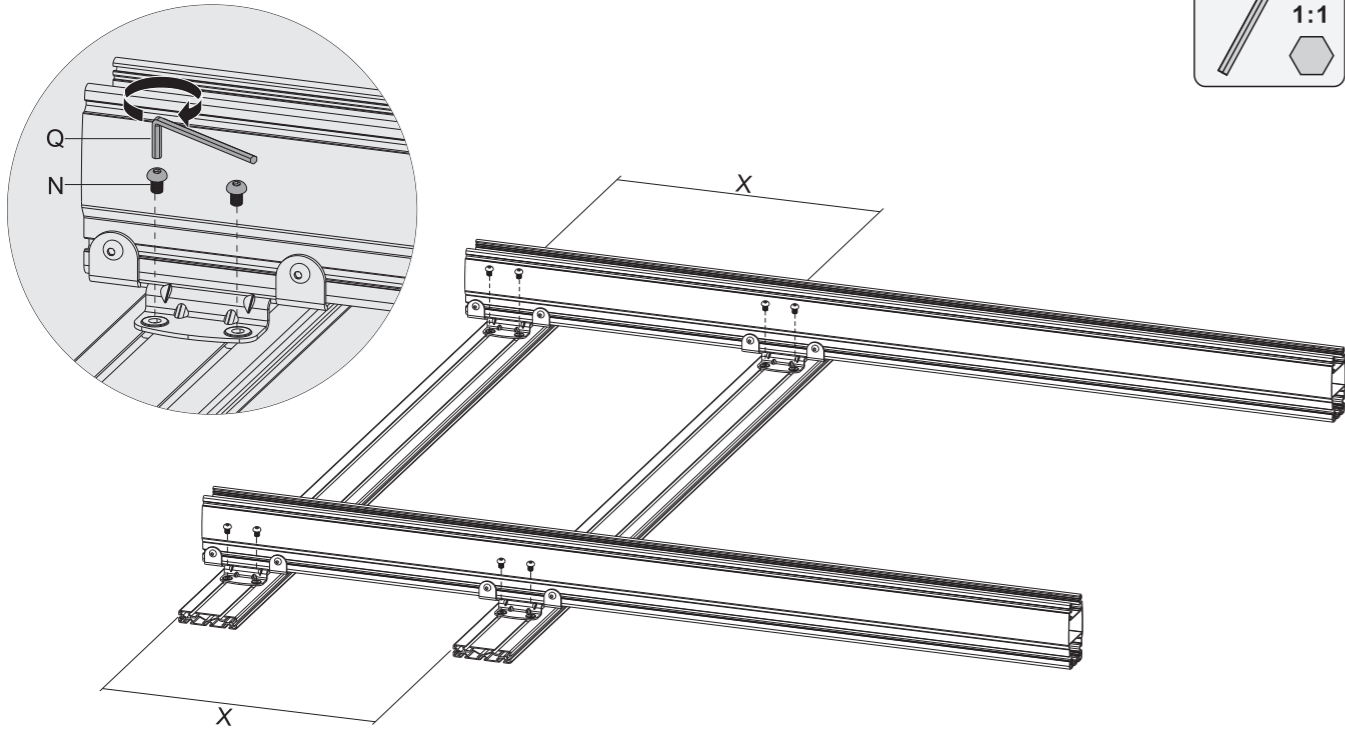
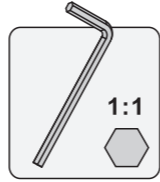

3. Install the End Cap

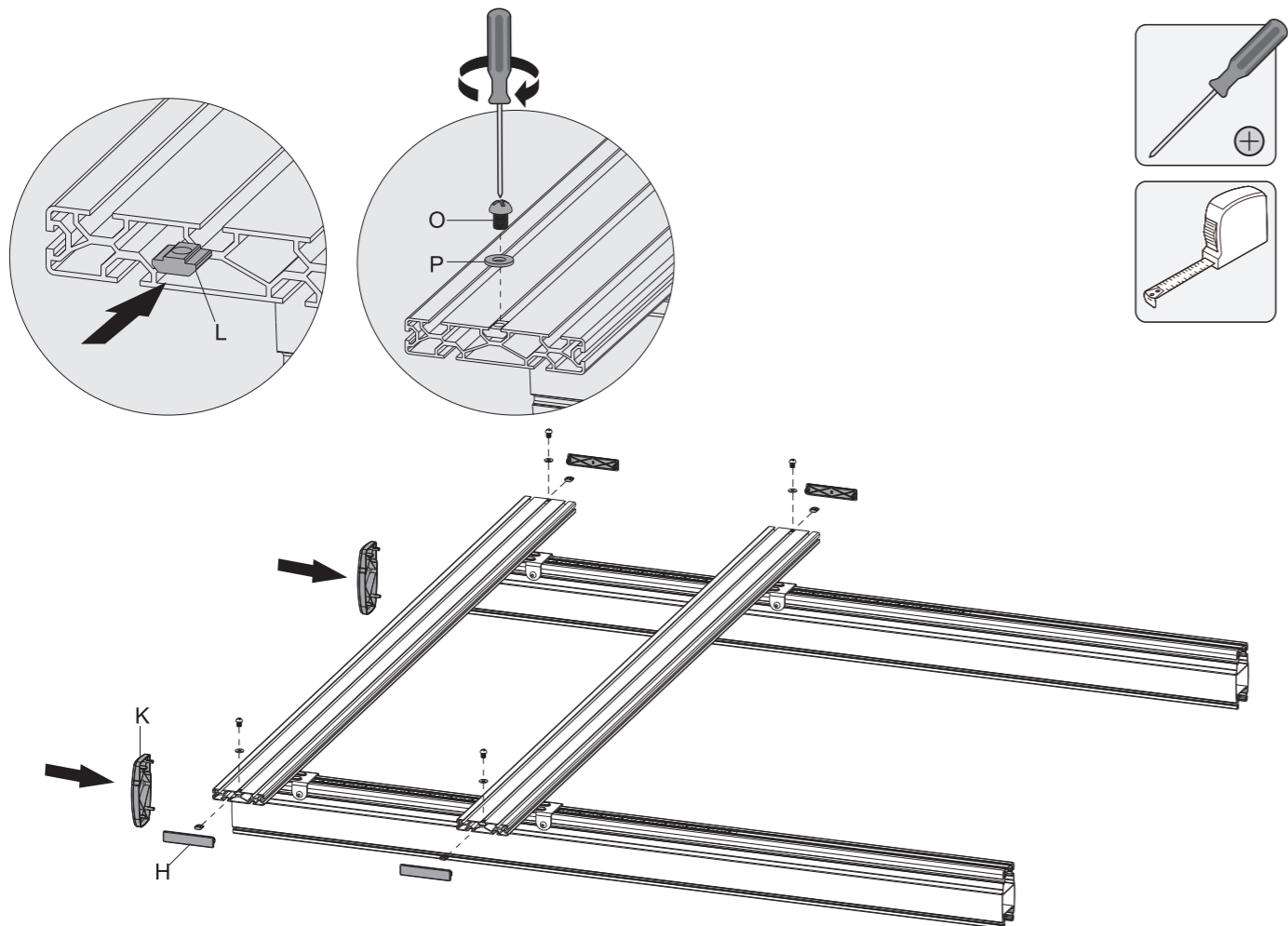

4. Assemble the Base

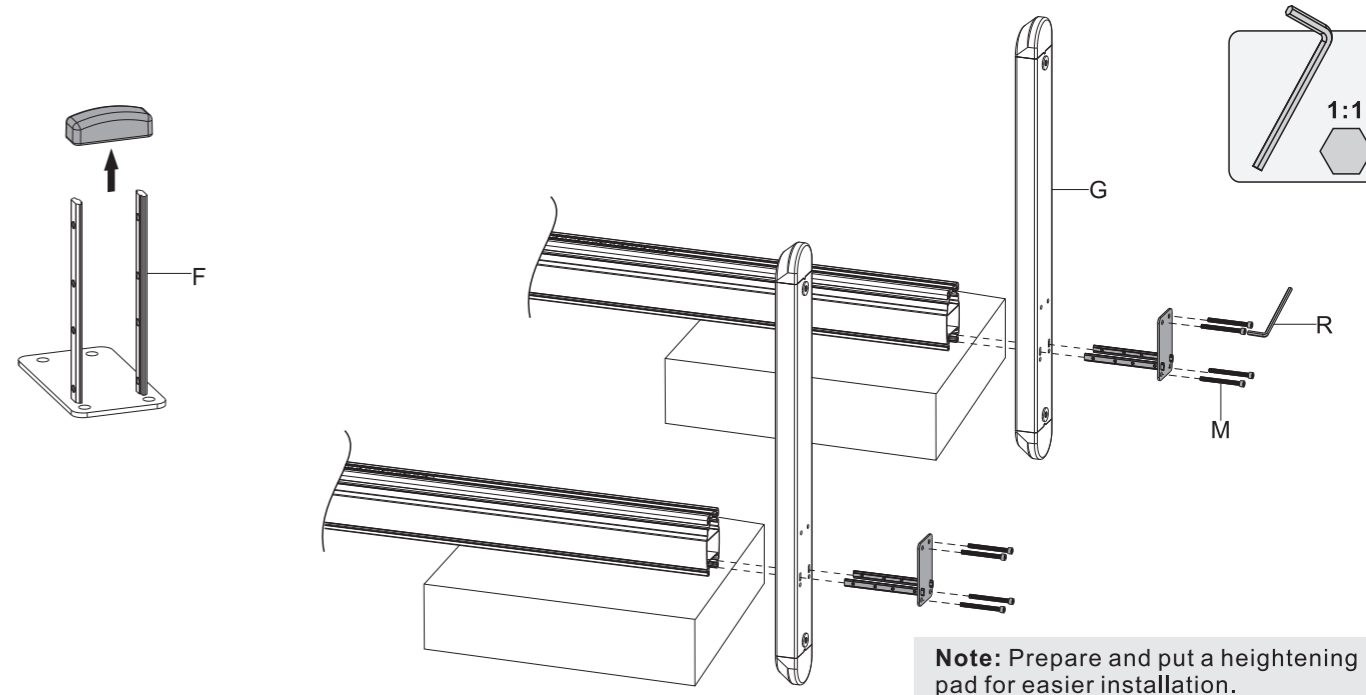
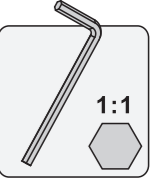

Note: Prepare and put a heightening pad for easier installation.

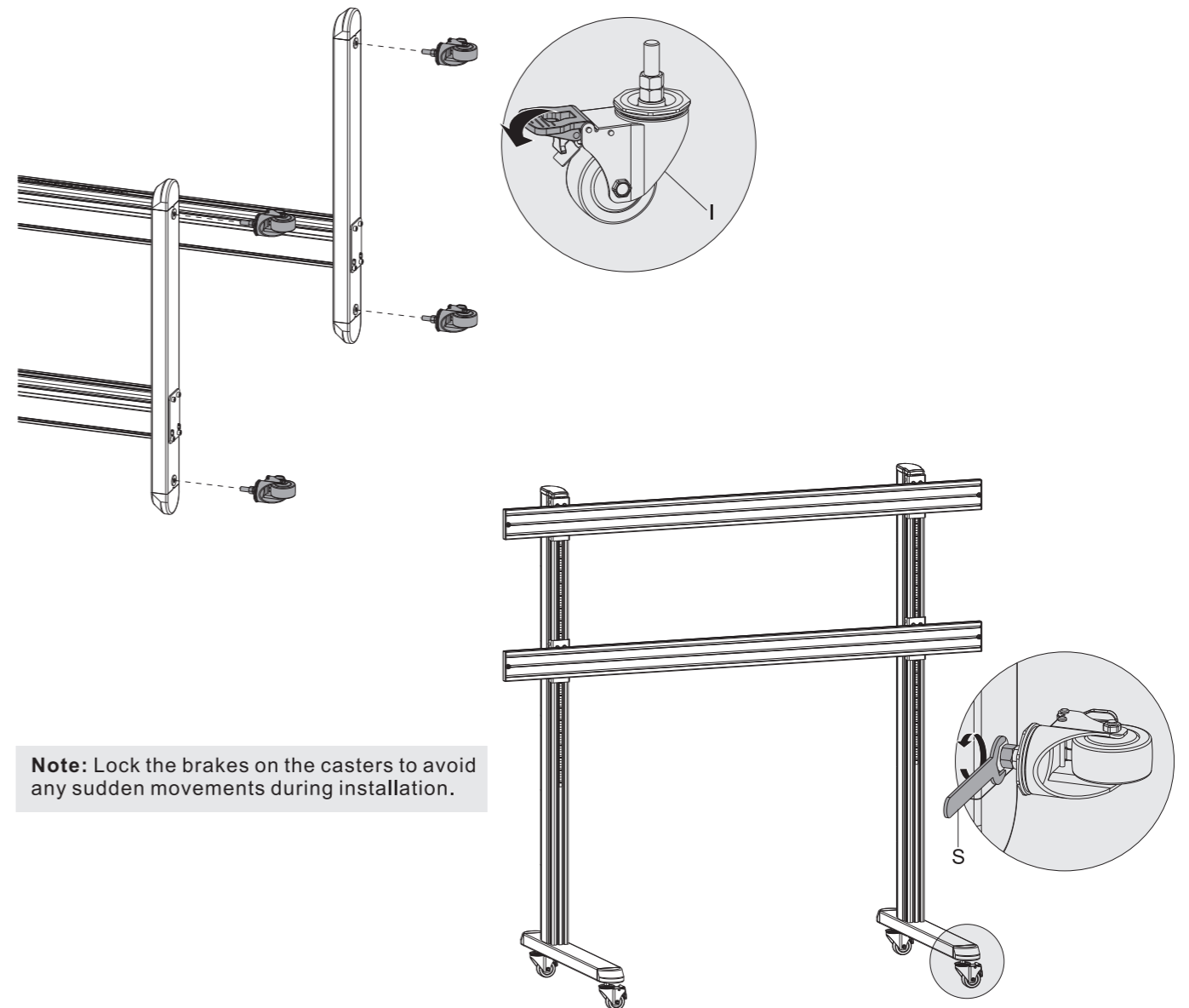

Note: Lock the brakes on the casters to avoid any sudden movements during installation.

5. Attach TV Bracket

With the arrow pointing up.

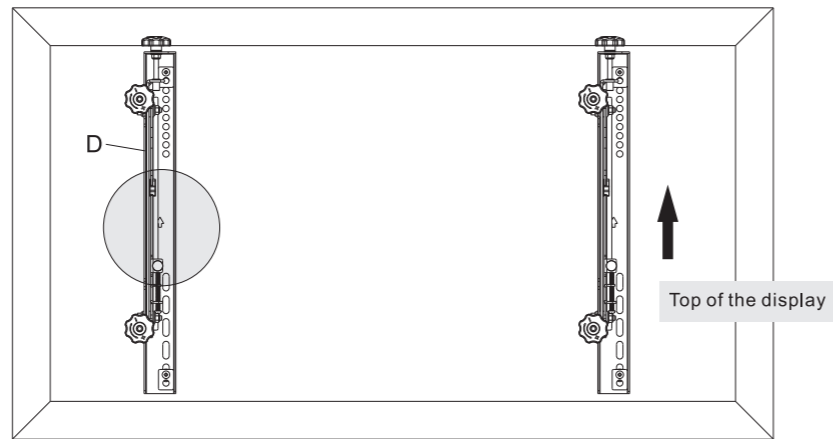
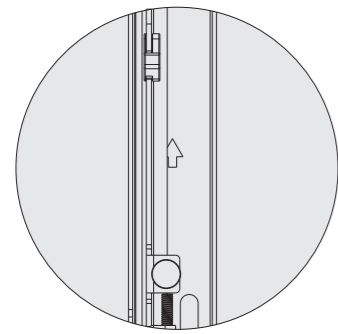

5a. Attach TV Bracket to Flat Back Screen

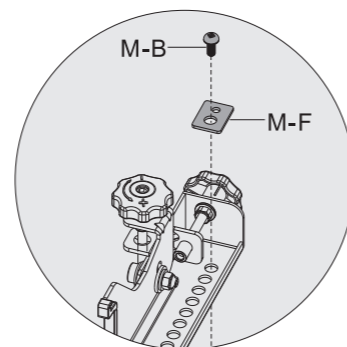
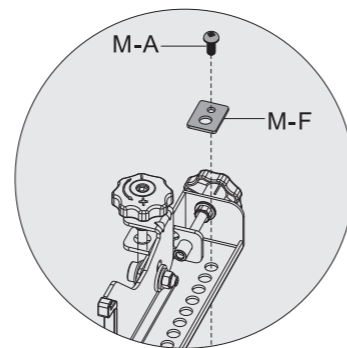
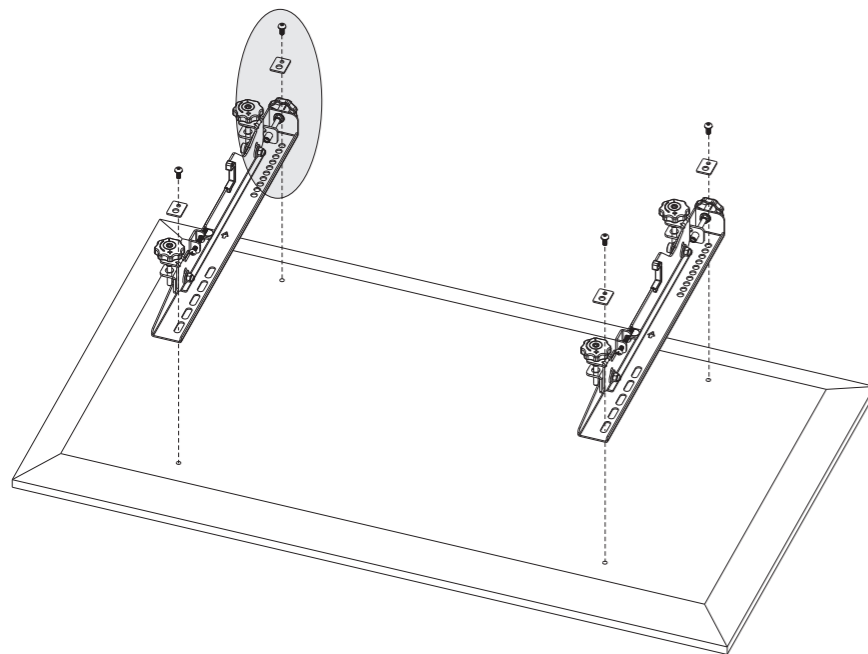
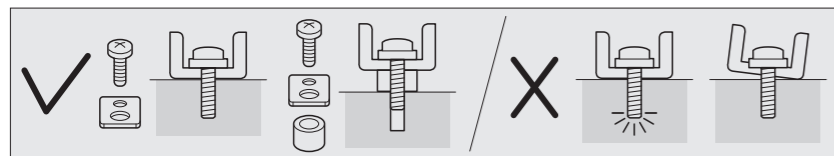

5b. Attach TV Bracket to Irregular Back Screen

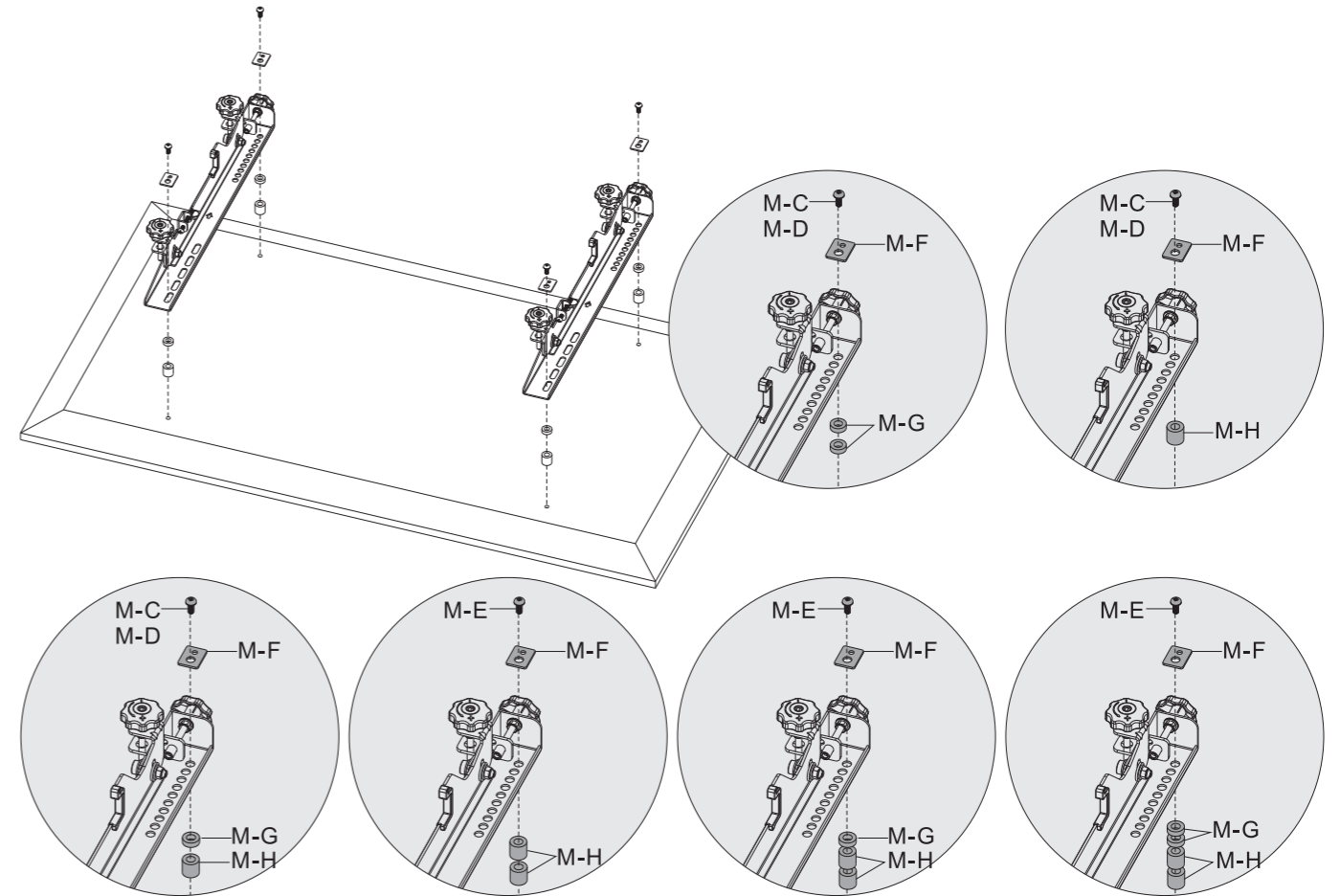

		1:1	
M-A			
M-C			
M-E			M-F
M-G			M-H

Note: Choose the appropriate screws, washers and spacers (if necessary) according to the type of screen.
 • Position the adapter brackets as close as possible to the center of the display.
 • Screw the adapter brackets onto the display.

Tighten all screws but do not over tighten.

6. Hang the Screen

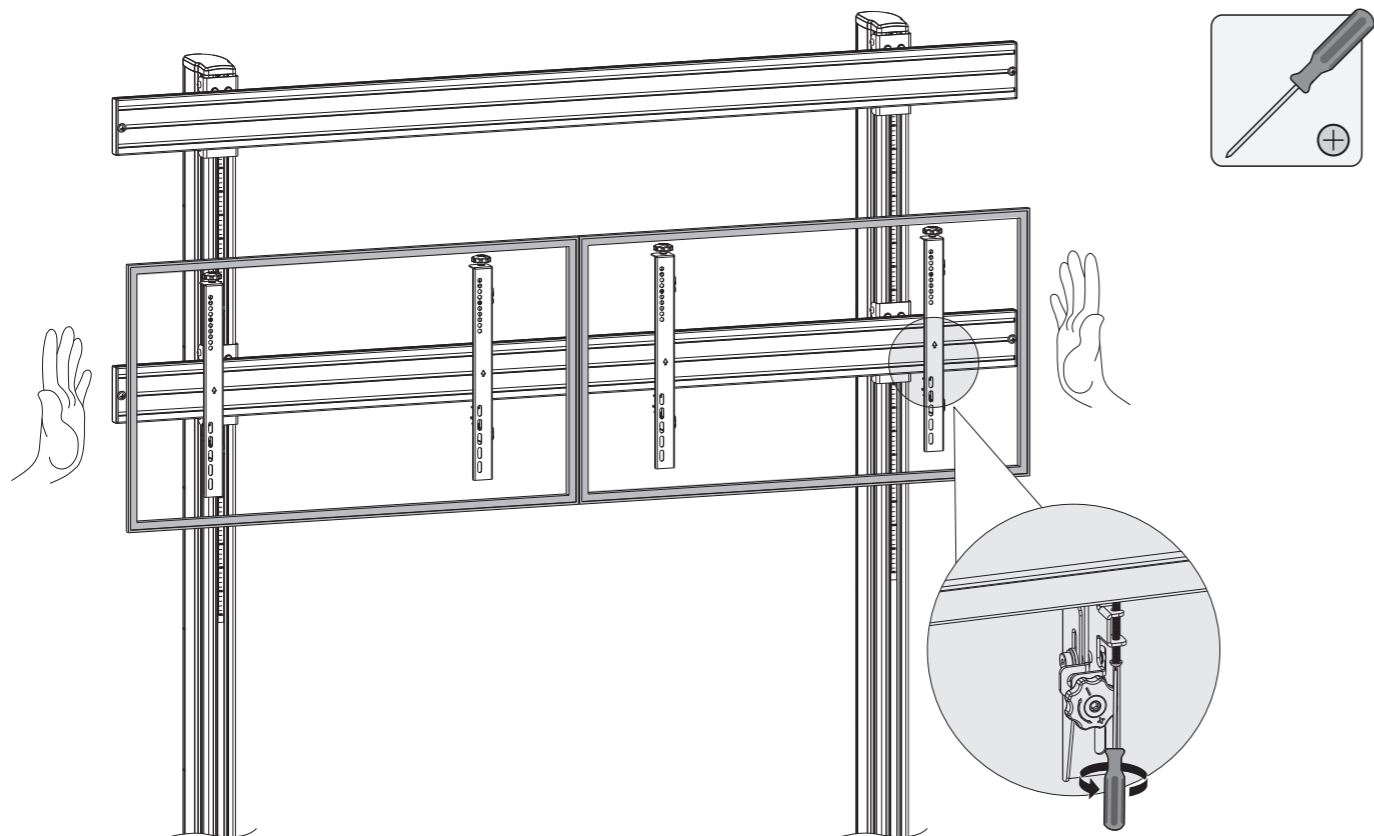
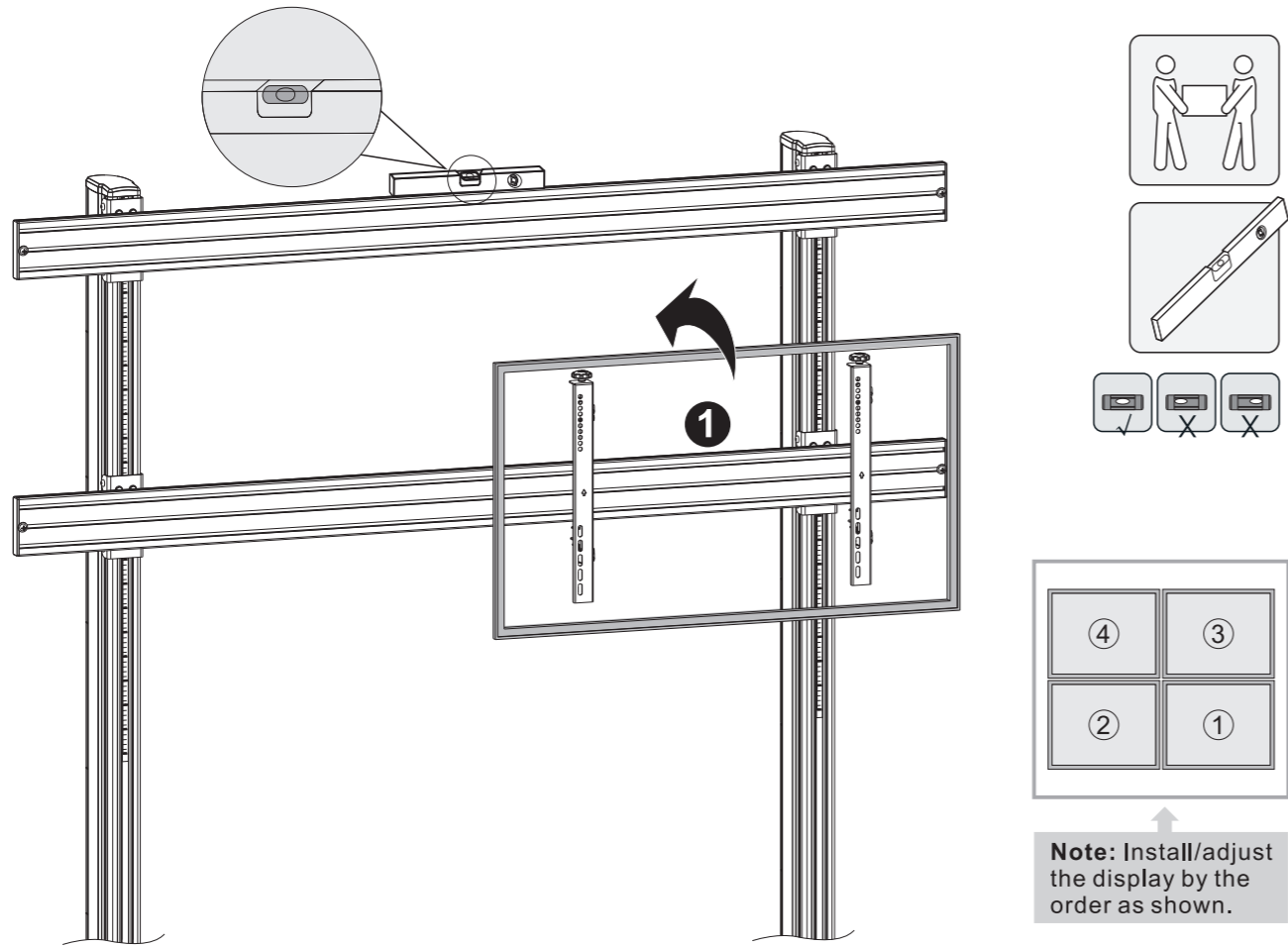

7. Precise Display Alignment

Z AXIS Adjustment Knob for Height Adjustment / Screen Leveling
Y AXIS Adjustment Knob for Depth Adjustment

