



Operating Manual

A 4411 4 CHANNEL STEREO MIXER

Optional Accessories

- A 4931 Local Input Remote Wall Plate (U/UTP Cat5)**
- A 4931V Local Input Remote Wall Plate (U/UTP Cat5)**
- A 4932 Local Input Box (U/UTP Cat5)**
- A 4935 Local Input Remote Wall Plate (U/UTP Cat5)**



A 4931 Local Input Plate

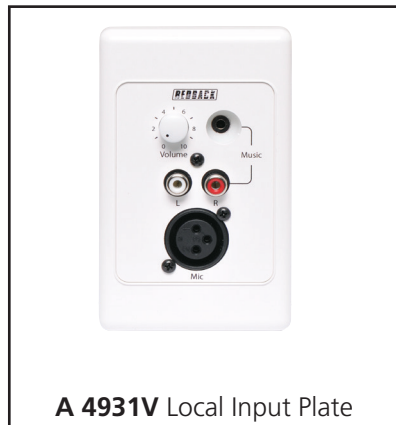

A 4931V Local Input Plate



A 4935 Local Input Plate



A 4932 Local Input Box

User manual revision number: 1.4 03/11/2022

IMPORTANT NOTE:

Please read these instructions carefully from front to back prior to installation. They include important setup instructions. Failure to follow these instructions may prevent the unit from working as designed.



You may be surprised to learn that Redback is still manufacturing hundreds of product lines right here in Australia. We have resisted the move offshore by offering our customers better quality products with innovations to save them time and money.

Our Balcatta production facility manufactures/assembles:

- Redback public address products
- One-shot speaker & grill combinations
- Zip-Rack 19 inch rack frame products

We strive to support local suppliers wherever possible in our supply chain, helping to support Australia's manufacturing industry.

Redback Audio Products

100% developed, designed & assembled in Australia.

Since 1976 we have been manufacturing Redback amplifiers in Perth, Western Australia. With over 40 years experience in the commercial audio industry, we offer consultants, installers and end users reliable products of high build quality with local product support. We believe there is significant added value for customers when purchasing an Australian made Redback amplifier or PA product.

Local support & feedback.

Our best product features come as a direct result of feedback from our customers, and when you call us, you speak to a real person - no recorded messages, call centres or automated push button options.

It's not only the assembly team at Redback who are employed as a direct result of your purchase, but hundreds more at local companies used in the supply chain.

Industry leading 10 year warranty.

There's a reason we have the industry leading DECADE warranty. It's because of a long tried and tested history of bullet-proof reliability. We've heard PA contractors tell us they still see the original Redford amplifier still in service in schools.

We offer this comprehensive parts & labour warranty on almost every Australian Made Redback public address product. This offers both installers and end users peace of mind that they will receive prompt local servicing in the rare event of any problems.

1.0 INTRODUCTION

Designed to meet the growing demands of PA systems utilising high power stereo amplifiers, it features 2 balanced microphone and 2 auxiliary inputs. Perfect for aerobics use, bars, bistros, sporting clubs.

Two sets of tone controls are provided; one for the microphone inputs and one for the auxiliary inputs.

Master volume is provided on the rear panel.

Inputs: Each microphone input incorporates a 3 pin balanced XLR socket on the rear panel with 15V DC phantom powering. An additional 6.35mm socket is provided on the front panel for input 1. Auxiliary inputs are stereo and use dual RCA sockets. A 3.5mm stereo jack socket (Music Input) is also provided for auxiliary input 2 on the front panel, suitable for the output of an MP3 player or similar.

Outputs: RCA sockets are provided for left and right line level and 3 pin XLR sockets for left and right 600Ω balanced outputs. Variable mute adjustment is provided for the microphones. This enables the microphone inputs to partially or fully mute the auxiliary inputs as desired.

2.0 FEATURES

- 2 microphone inputs
- Phantom power on Mic inputs (15V DC)
- 2 line inputs
- Separate tone controls for line and microphones
- Stereo outputs
- 1RU 19" rack mount case
- Master volume on rear panel
- Adjustable line muting
- Front panel mount microphone
- Subwoofer output (rear panel)
- LED VU meter
- VOX active indicator
- Signal Present indicator
- 24V DC input
- 24V DC battery back up terminals
- 10 Year Warranty
- Australian designed & assembled

3.0 WHAT'S IN THE BOX

A 4411 Four Channel Stereo Mixer
24V 1A DC Plugpack
Instruction Booklet

4.0 FRONT PANEL GUIDE

Fig 1 shows the layout of the A 4411 front panel.

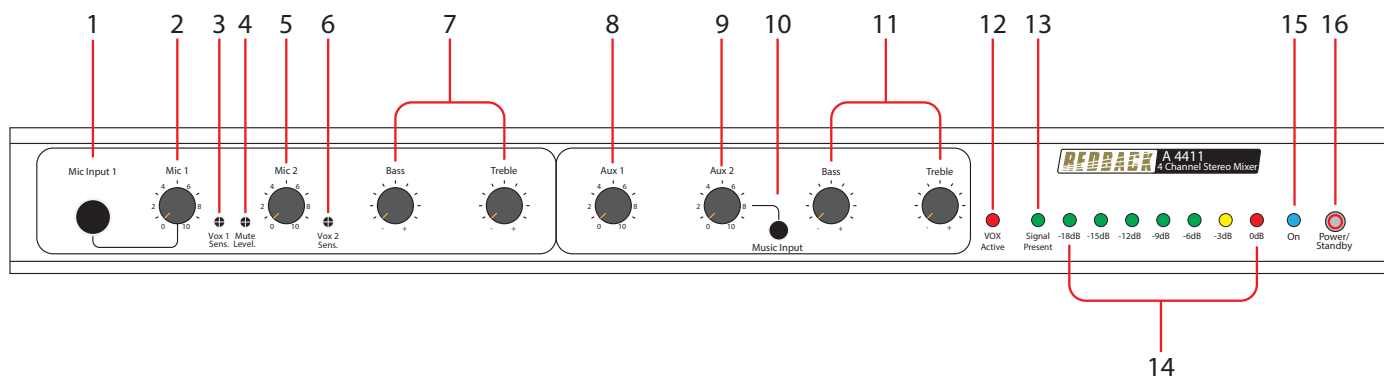

Fig 1

- 1 Mic 1 Input**
This 6.35mm socket is connected in parallel with the rear Mic 1 input. Either input can be used and both have 15V DC phantom power.
- 2 Mic 1 volume control**
Use this control to adjust the output volume of Mic 1.
- 3 VOX 1 Sensitivity**
This trimpot is used to set the VOX sensitivity of Mic 1.
- 4 Mute Level**
This trimpot is used to adjust the mute level, which enables the microphone inputs to partially or fully mute the auxiliary inputs (when the VOX circuit is active). VOX circuit needs to reactivate each time an adjustment is made for the effect to take place.
- 5 Mic 2 volume control**
Use this control to adjust the output volume of Mic 2.
- 6 VOX 2 Sensitivity**
This trimpot is used to set the VOX sensitivity of Mic 2.
- 7 Microphones Bass and Treble Controls**
Use these to adjust the Bass and Treble of the microphone inputs.
- 8 Aux 1 volume control**
Use this control to adjust the output volume of Aux 1.
- 9 Aux 2 volume control**
Use this control to adjust the output volume of Aux 2.
- 10 Music input**
This input will override AUX Input 2 when connected. Use this for connection of portable music players.
- 11 Aux Inputs Bass and Treble Controls**
Use these to adjust the Bass and Treble of the auxiliary inputs.
- 12 VOX Active Indicator**
This LED indicates when the VOX circuit is active
- 13 Signal Presence Indicator**
This LED indicates when a signal is present at any of the inputs.
- 14 LED VU Meter**
This LED bargraph provides a visual indication of the output signal.
- 15 On/Fault Indicator**
This led indicates when the unit has power if the LED is blue. If the LED is red a fault has occurred with the unit.
- 16 Standby Switch**
When the unit is in standby mode this switch will illuminate. Press this button to switch the unit ON. Once the unit is ON the On indicator will illuminate. Press this switch again to put the unit back in standby mode.

5.0 REAR PANEL CONNECTIONS

Fig 2 shows the layout of the A 4411 rear panel.

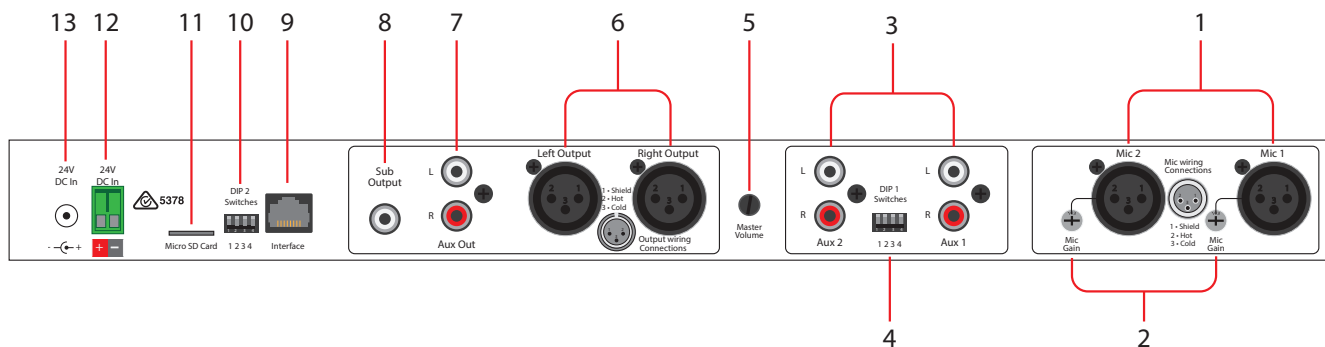

Fig 2

1 Microphone Inputs 1 & 2

There are two microphone inputs which all incorporate a 3 pin balanced XLR. Phantom power (15V DC) is available at each Mic input. Mic 1 is connected in parallel with the front 6.35mm Socket.

2 Mic Gain

These trimpots are used to adjust the microphone gain of the Mic 1 and Mic 2 inputs (including the front Mic 1 socket).

3 RCA Inputs 1 & 2

The Aux inputs are dual stereo RCA connectors. The input sensitivity of these inputs can be adjusted by DIP 1.

4 Dip Switches DIP1

These are used to set the input sensitivity of Aux 1 and Aux 2 to either 100mV or 1V.

Switch 1 sets Aux 2 input sensitivity: OFF -100mV, ON - 1V.

Switch 4 sets Aux 1 input sensitivity: OFF -100mV, ON - 1V.

Switches 2 & 3 are not used.

5 Master Volume

Use this to adjust the master volume output from the mixer.

6 XLR Outputs

XLR balanced outputs (600Ω) are provided for the left and right outputs.

7 Aux Out

Dual RCA's provide a line level output for recording purposes or to pass the output on to another amplifier.

8 Sub Out

A single RCA which provides a dedicated sub output for use with a sub woofer amplifier.

9 RJ45 Interface

This is for connection of the optional Redback® A 4931, A 4931V, A 4932 and A 4935 local input products.

10 DIP 2

Switch 1 activates the Microphone VOX circuit. When this DIP switch is set to ON, Mic1 and Mic2 VOX mute all other inputs.

Switches 2 - 4 are not used.

11 Micro SD Card

This has been provided in case the mixer requires a firmware update (Note: A Micro SD card is not supplied).

12 24V DC Input (Backup)

Connects to a 24V DC backup supply with at least 1 amp current capacity. (Please observe the polarity)

13 24V DC input

Connects to a 24V DC Plugpack with 2.1mm Jack (supplied).

Redback® A 4411 4 Channel Stereo Mixer

6.0 WIRING CONNECTIONS

Figure 3 demonstrates a basic install with four input sources.

The output of the mixer is fed into a power amplifier which drives the speakers.

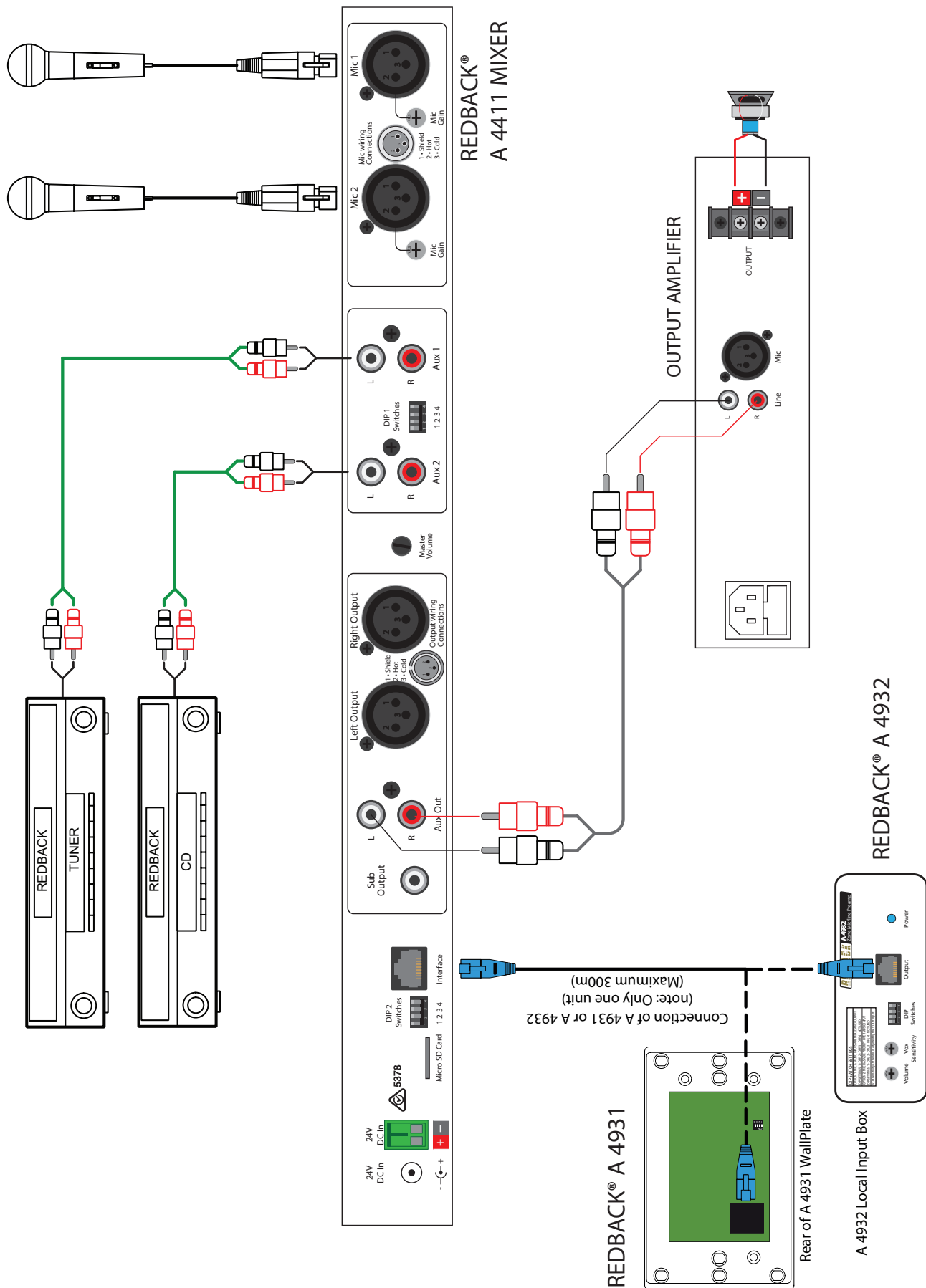

Fig 3

6.1 Local Microphone/Line Input Wall Plate Or Box

The A 4931, A 4931V and A 4935 Zone Mic/Line Wall Plates or A 4932 Zone Mic/Line Preamp Box provide a way of overriding the inputs of the A 4411 with a remotely located local input source. An example may be a mobile phone for background music or a microphone for speeches at a wedding function.

The wall plates and box have connections for 3 pin XLR microphones, dual RCA line level inputs and a 3.5mm line level input for portable devices.



Fig 4. Front View of A 4931, A 4931V and A 4935 Local Input Wall Plates and A 4932 Local Input Box

The local input sources have to be connected to the A 4411 via a Cat5e cable and is connected as shown in fig 3.

NOTE: The A 4411 mixer can have only one of the A 4931, A 4931V, A 4935 local input plates or A 4932 local input boxes connected.

6.2 A 4931, A 4931V, A 4932 and A 4935 DIP Switch Settings

The A 4931, A 4931V, A 4932 and A 4935 have a set of DIP switches on the rear which determine how the audio is output. The DIP switches are labelled 1) VOX BOTH, 2) VOX ENABLE, 3) VOX OUTPUT.

When the A 4931/32/35 is used with the A 4411 there are only two possible audio output options.

1) The audio from the A 4931/32/35 microphone input and the line and/or music inputs are mixed together and output to the A 4411. This input is then mixed in with the Mic and RCA inputs of the A 4411.

DIP Switches set as follows: 1-OFF ,2-OFF, 3-OFF. Switch 4 is not used.

2) The A 4931/32/35 microphone input/s have VOX priority over the line and music inputs. I.e. the audio from the line/Music inputs will be over ridden by the Mic input/s when a microphone is used.

The audio from the A 4931/32/35 will then VOX mute the RCA inputs of the A 4411 and be mixed in with the Mic1 and Mic2 inputs of the A 4411.

DIP Switches set as follows: 1-OFF ,2-OFF, 3-ON. Switch 4 is not used.

The VOX sensitivity of the microphone is adjusted by the trimpot on the rear of the A 4931/32 or the pot adjustment on the front of the A 4935 labelled "VOX" or "VOX sensitivity".

Redback® A 4411 4 Channel Stereo Mixer

7.0 TROUBLE SHOOTING

If the REDBACK A 4411 mixer fails to deliver the rated performance, check the following:

No Power, No Lights

The standby switch is used to turn the unit on. Make sure this switch has been pressed.
Make sure mains power switch is on at the wall.
Check the supplied plugpack is connected correctly.

DIP switch changes not effective

Turn the unit OFF before changing DIP switch settings. Settings become effective after power is returned.

8.0 FIRMWARE UPDATES

It is possible to update the firmware for the A 4411 Mixer by downloading the relative update version from redbackaudio.com.au if available.

To perform an update, follow these steps.

- 1) Download the Zip file from the website.
- 2) Insert a Micro SD card into your PC.
- 3) Extract the contents of the Zip file to the root folder of the Micro SD Card.
- 4) Rename the extracted .BIN file to "update.BIN".
- 5) Remove the Micro SD card from the PC following windows safe card removal procedures.
- 6) With the power turned OFF, insert the Micro SD card into the back of the A 4411.
- 7) Turn the A 4411 ON. The unit will check the SD card and if an update is required the A 4411 will perform the update automatically.

9.0 A 4411 SPECIFICATIONS

INPUTS: 2 x Mic balanced 600Ω
..... 2 x Line Stereo 10KΩ

OUTPUTS (STEREO):600Ω balanced 0dBm

DISTORTION:

Mic inputs:less than 0.3%

Line inputs: less than 0.3%

FREQUENCY RESPONSE:

Mic: 30Hz-15kHz

Line:20Hz-30kHz

S/N ratio: -78dB

Sensitivity:Mic 1.5mV, line 400mV

Phantom power:Nominal 12-15V DC

Output connectors:3 pin XLR balanced
.....Stereo RCA

INPUT CONNECTORS:

Mic:3 pin XLR balanced rear panel

.....6.35mm jack balanced front panel

Line inputs:RCA stereo rear panel

..... 3.5mm stereo jack front panel

CONTROLS:

Mic inputs:Volume

Line inputs:Volume

Bass:±12dB @ 100Hz

Treble:±12dB @ 10kHz

Master Volume:On rear panel

VOX sensitivity (Mic 1 & 2):On front panel

Mute level Aux 1 & 2 (Combined): On front panel

Mic gain (Mic 1 & 2): On rear panel

Indicators:Power on LED

Power supply:24V DC

Protection:.....internal polyswitch

Dimensions:482W x 175D x 44H mm

Weight:≈3kg

Colour:.....Black

* Specifications subject to change without notice