



OVERVIEW:

The Redback® A 4465 has the ability to interface to Bluetooth audio devices such as a mobile phone or tablet, and convert the bluetooth input signal to a balanced high level output. The output signal is carried via Cat5e/6 cable, (suitable for distribution up to 300m without interference) back to Redback® compatible UTP receivers.

BLUETOOTH FUNTIONALITY

When the A 4465 is first powered up, or after the pairing has been reset by holding down the “Press to Pair” button, the Bluetooth connection is available (or connectable). The BT Status LED will flash blue in this mode.

Press the button “Press to pair” to pair the A 4465 to your phone/device. The BT status LED will flash red/blue in this mode. The connection labelled “A4465_REDBACK_BT” should appear in your pairing list. Pair as per your devices standard procedure. The BT status LED will be a solid blue when connected.

To clear the pairing list or to kick a user off the bluetooth connection, hold down the “Press to Pair” button until the blue LED flashes quickly. The Bluetooth connection is now available.

BLUETOOTH PAIRING TIMEOUT

The pairing timeout can be adjusted via DIP switch 2.

- 1) NO Timeout - Set DIP switch 2 to “OFF”.
- 2) Pairing timeout set to 2 minutes - Set DIP switch 2 to “ON”

BLUETOOTH AUTO CONNECT

The wall plate can be configured to auto connect when coming back into bluetooth range.

- 1) No Auto connection - Set DIP switch 3 to “OFF”
- 2) Autoconnect when back in range - Set DIP switch 3 to “ON”

BLUETOOTH APP

A bluetooth connection APP will be made available for Android devices.

The APP will allow custom labelling of the connection name and can apply a PIN to the connection. The default name for the connection is A4465_REDBACK_BT.

User manual revision number: 1.0 03/05/2024

Redback® A 4465 Bluetooth Receiver Wallplate

To allow the APP to connect to the A 4465, and change the label name and/or PIN, follow these steps.

- 1) set DIP switch 1 to "ON". The BT Status LED will flash RED (Note: It may take up to 3 seconds). Once a connection to the APP has been established the LED will become solid RED.
- 2) Change the label and/or PIN using the APP.
- 3) set DIP switch 1 to "OFF"

CONNECTIONS

Figure1 illustrates connection of the A 4465 to the Redback® A 4946 Cat5 to RCA extender, to provide an RCA output for connection to an amplifier or mixer. Check the Redback websites for other compatible Redback® UTP receivers (search for "UTP Solutions"). The A 4465 can also provide a local bluetooth input for use with a Redback® A 4480B matrix system as illustrated in figure 2 (Note: the A 4465 must be connected to an A 4495 Zone selector plate).

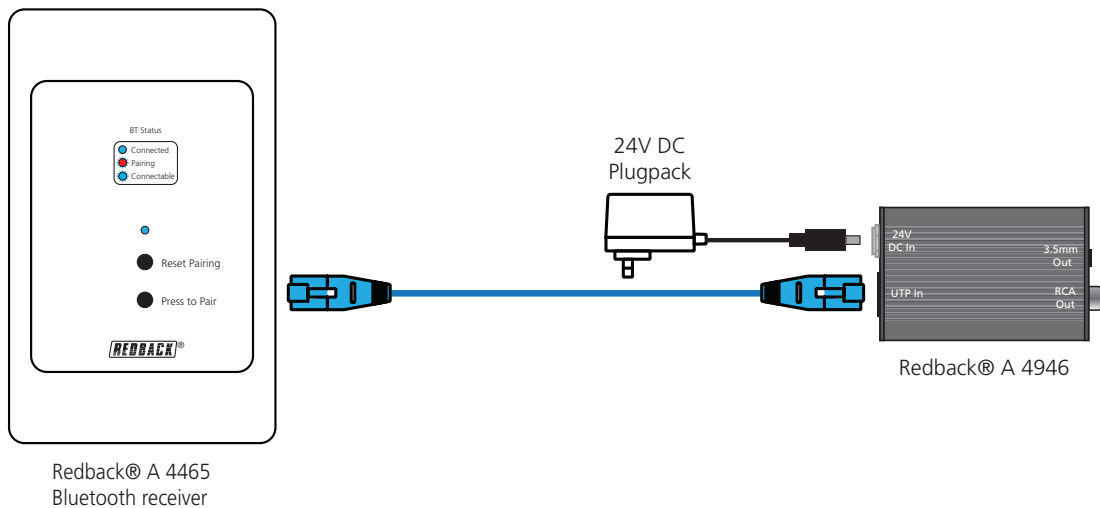

Fig 1.

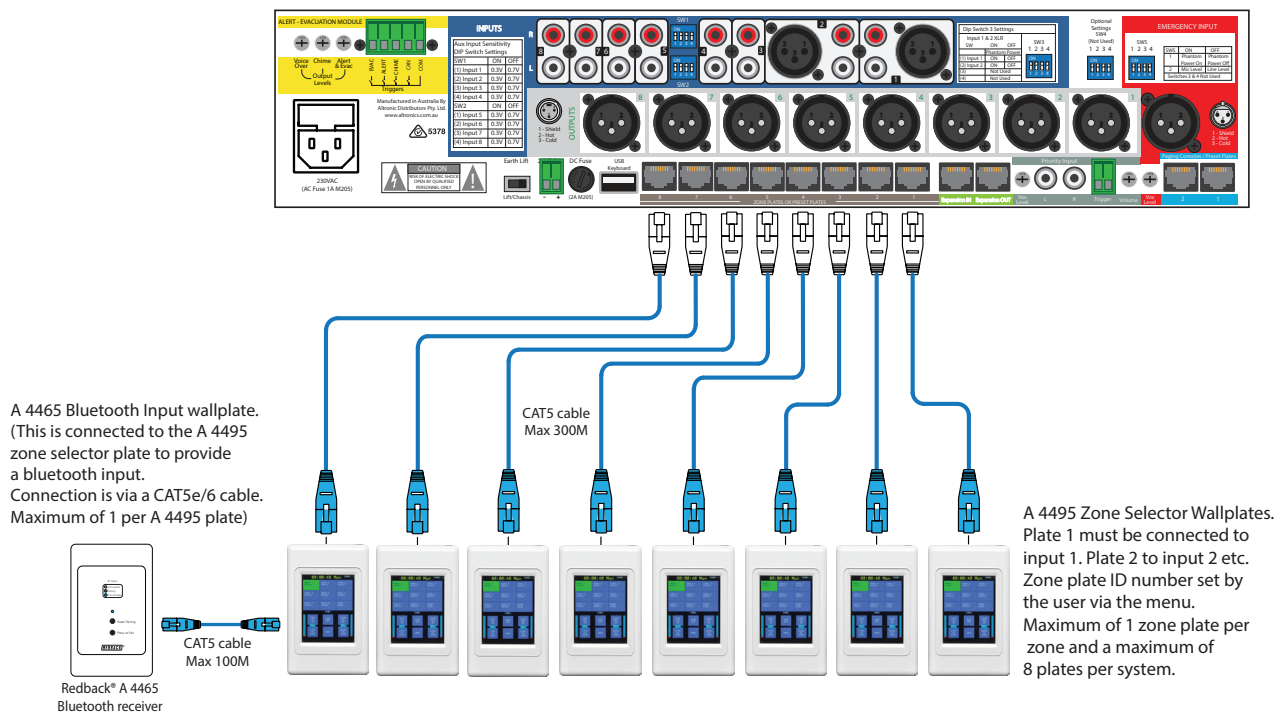

Fig 2.

All Australian made Redback products are covered by a 10 year warranty.

Should a product become faulty please contact us to obtain a return authorisation number. Please ensure you have all the relevant documentation on hand. We do not accept unauthorised returns. Proof of purchase is required so please retain your invoice.