

Operating Manual A 4510B Yearly Timer

Redback® Proudly Made In Australia

IMPORTANT NOTE:

Please read these instructions carefully from front to back prior to installation. They include important setup instructions. Failure to follow these instructions may prevent the unit from working as designed.



Made In Australia

You may be surprised to learn that Redback is still manufacturing hundreds of product lines right here in Australia. We have resisted the move offshore by offering our customers better quality products with innovations to save them time and money.

Our Balcatta production facility manufactures/assembles:

Redback public address products
One-shot speaker & grill combinations
Zip-Rack 19 inch rack frame products

We strive to support local suppliers wherever possible in our supply chain, helping to support Australia's manufacturing industry.

Redback Audio Products

100% developed, designed & assembled in Australia.

Since 1976 we have been manufacturing Redback amplifiers in Perth, Western Australia. With over 40 years experience in the commercial audio industry, we offer consultants, installers and end users reliable products of high build quality with local product support. We believe there is significant added value for customers when purchasing an Australian made Redback amplifier or PA product.

Local support & feedback.

Our best product features come as a direct result of feedback from our customers, and when you call us, you speak to a real person - no recorded messages, call centres or automated push button options. It's not only the assembly team at Redback who are employed as a direct result of your purchase, but hundreds more at local companies used in the supply chain.

Industry leading 10 year warranty.

There's a reason we have the industry leading DECADE warranty. It's because of a long tried and tested history of bullet-proof reliability. We've heard PA contractors tell us they still see the original Redford amplifier still in service in schools.

We offer this comprehensive parts & labour warranty on almost every Australian Made Redback public address product. This offers both installers and end users peace of mind that they will receive prompt local servicing in the rare event of any problems.

CONTENTS

	Page
1.0 Overview	
1.1 Introduction	4
1.2 Features	4
1.3 What's in the box	4
1.4 Front panel guide	5
1.5 Rear panel connections	6-7
2.0 Setup	
2.1 Initial Setup	8
2.2 Setting the current Time	8
2.3 Setting the current Date	8
2.4 Audio Connections	9
2.5 DIP Switch settings	9
2.6 24V Output Connections	9
2.7 Battery Backup (Of Time)	10
3.0 Network Access	10
4.0 Firmware Update	10
5.0 Troubleshooting	
5.1 Symptoms and Remedies	11
6.0 Specifications	12

A 4510B Yearly Timer with Network Access

1.0 OVERVIEW

1.1 INTRODUCTION

The A 4510B is an incredibly versatile, and easily programmed yearly timer housed in a convenient 2RU rack or desk mount chassis. The unit can be programmed for a maximum of 250 timing events for each day of the year. The timing events are programmed with Windows based software via a user friendly calendar layout.

When a timing event is activated, an MP3 audio file will be played and output through the dual RCA line level output. There are 99 audio playback options for the timing events, which include the Bell, Prebell, Music and outputs 5-99. A Micro SD card which is supplied, houses all the MP3 files to be played as well as storing all the timing events (Note: The audio files must be in MP3 format). The Prebell, Music and outputs 5-99 can be setup for random play of MP3 files, making the unit ideal for "Call to Class" playback of music which changes each time these outputs are activated.

The events when activated also trigger the 24V outputs available on the rear of the unit. Separate 24V DC outputs are available for each of the Prebell, Bell and Music outputs, as well as a common 24V DC output which is activated for all output conditions.

The timing events can also be programmed to trigger the "Relay Only" out (and in turn the common 24V Out), with no audio output. This is activated by setting the output to the "relay" option in the programming setup.

The unit features "Daylight Savings" mode which when activated automatically adjusts the clock time by one hour at the user programmed dates.

The internal clock has a battery backup (CR2032 supplied) in case of power failure. (Note: This will only backup the time, it will not power the unit in the event of a power failure).

1.2 FEATURES

- MP3 audio format for Bell, Prebell and Music timing outputs
- Random play of audio files for Prebell and Music activations
- Easy Windows based software timing event setup
- Daylight savings mode
- Local push button operation of Bell
- Switched 24VDC output for Bell, Prebell, Music and relay only (No audio) output activations
- Bell trigger for remote activation of the bell
- Pluggable screw terminal connections
- Auxiliary level output
- Battery backup of current time
- 24V DC operation
- Standard 2U 19" rack mount case
- Suitable for any amplifier with an auxiliary input
- 10 Year Warranty
- Australian Designed and Manufactured

1.3 WHAT'S IN THE BOX

A 4510B Yearly School Timer
Micro SD card
24V 1.5A DC Plugpack
Instruction Booklet
Programming Booklet

1.4 FRONT PANEL GUIDE

Figure 1 shows the layout of the A 4510B front panel.

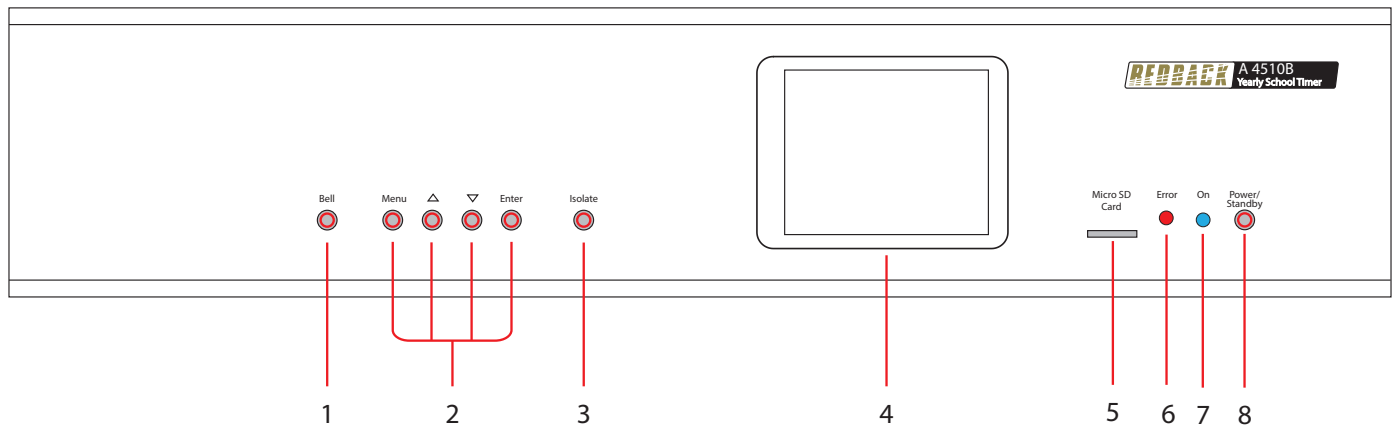

Fig 1

- 1 Bell Tone Activation Switch**
This switch is used to manually activate the Bell tone. It may need to be pressed for up to 2 seconds to activate.
- 2 Menu and Navigation Switches**
These switches are used to navigate the menu functions of the unit.
- 3 Isolate Switch**
This switch is used to isolate the timing functions of the unit. Once activated all the timing functions of the unit will be disabled. Press this button again to restore the unit to normal timing operation.
- 4 LCD Display**
This displays the current time and other timing functions.
- 5 Micro SD card**
This is used to store the MP3 audio files for the Prebell, Bell and Music playback. The Windows based software for programming the calendar and the timing configuration files are also stored on this card. (More details in section 2.1).
- 6 MP3 Error Indicator**
This LED indicates the unit has a fault condition with the MP3 playback.
- 7 On Indicator**
This LED indicates the unit has power.
- 8 Power/Standby Switch**
When the unit is in standby mode this switch will illuminate. Press this button to switch the unit ON. Once the unit is ON the On indicator will illuminate. Press this switch again to put the unit back in standby mode.

A 4510B Yearly Timer with Network Access

1.5 REAR PANEL CONNECTIONS

Figure 2 shows the layout of the A 4510B rear panel.

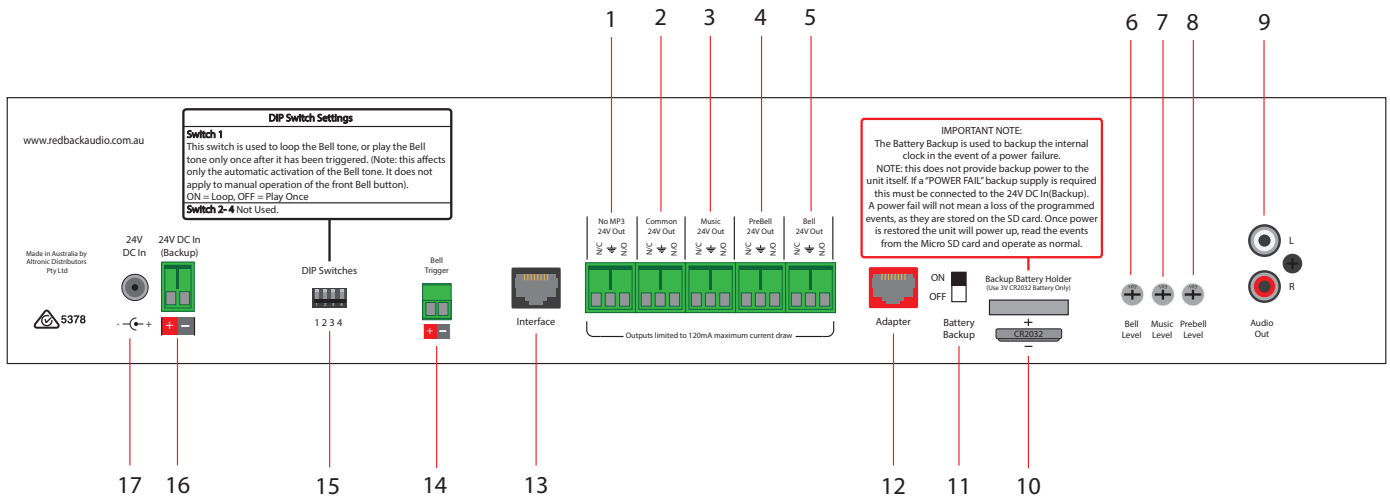

Fig 2

1 Relay Only 24V Out

This is a 24V DC output which is activated when the relay only (No MP3 option) is activated. The terminals provided can be used for "Normal" or "Failsafe" modes (see section 2.6 for more details).

2 Common 24V Out

This is a common 24V DC output which is activated when any of the Prebell, Bell, or Music tones or the Relay only option are activated. The terminals provided can be used for "Normal" or "Failsafe" modes (see section 2.6 for more details).

3 Music 24V Out

This is a 24V DC output which is activated when the Music tone is activated. The terminals provided can be used for "Normal" or "Failsafe" modes (see section 2.6 for more details).

4 Prebell 24V Out

This is a 24V DC output which is activated when the Prebell tone is activated. The terminals provided can be used for "Normal" or "Failsafe" modes (see section 2.6 for more details).

5 Bell 24V Out

This is a 24V DC output which is activated when the Bell tone is activated. The terminals provided can be used for "Normal" or "Failsafe" modes (see section 2.6 for more details).

6 Bell Volume

Adjust this trimpot to adjust the Bell playback volume.

7 Music Volume

Adjust this trimpot to adjust the Music playback volume.

8 PreBell Volume

Adjust this trimpot to adjust the PreBell playback volume.

9 Audio Out RCA Connectors

Connect these outputs to the input of the background music amplifier.

10 Backup Battery

Replace this battery with a 3V CR2032 only. Remove by pulling the battery. Note: The positive side of the battery faces upward.

11 Backup Battery Switch

Use this switch to activate the backup battery. (Note: This will only backup the time, it will not power the unit in the event of a power failure).

- 12 RJ45 Adapter**
This RJ45 port is for future connection of Redback devices.
- 13 RJ45 Interface**
This RJ45 port is for future connection of peripheral devices.
- 14 Bell Trigger**
Short these contacts to trigger the Bell Function.
- 15 Dip Switches**
These are used to select various options. Refer to DIP Switch Settings section.
- 16 24V DC Input (Backup)**
Connects to a 24V DC backup supply with at least 1 amp current capacity (Please observe the polarity).
- 17 24V DC input**
Connects to a 24V DC Plugpack with 2.1mm Jack. (The unit is supplied with a 24V DC 2 Amp plugpack).

2.0 SETUP GUIDE

2.1 INITIAL SETUP

Apply 24 Volts DC to the unit by connecting the supplied 24V DC plugpack and switch the unit ON.

The LCD screen should display "REDBACK A 4510B" for a couple of seconds before it performs an Micro SD card check. If the Micro SD card is not fitted the LCD will display "

SD card ERROR

CARD NOT FOUND

If this is the case make sure the Micro SD card is fitted correctly.

(NOTE: The unit will not function unless the Micro SD card is inserted).

With the Micro SD card fitted the unit should perform a self check of the card (CHECKING SDCARD). The check involves searching for the relevant folders, configuration file and audio files.

The search information should come up on the screen and disappear after a couple of seconds, if the check is successful.

If there is an issue, the Self Check screen will flash and continue to be cycle through and display again until all issues are resolved. *NOTE: You can Press and Hold the "ENTER" button to keep this information on the screen.*

- If audio files for the Bell, Music and Prebell don't exist the self check will display a fault.
- If this is the first time the unit is powered up and a calendar hasn't been programmed the unit will display a fault.

To program the calendar and/or check the audio files, refer to the included "Software Programming Guide".

Once the calendar has been programmed and it has been confirmed that audio files for the Bell, Music and Prebell exist, insert the Micro SD card again.

If the self check is successful then the unit will display the "Current Time" screen and the upcoming events.

2.2 SETTING THE CURRENT TIME

Press the "Menu" button on the front of the timer. The unit is now in "Menu Mode" and the screen should display the "CLOCK ADJUST" and "DATE ADJUST" options.

Use the UP and DOWN buttons to navigate through the options.

Press the ENTER button when the CLOCK ADJUST option is highlighted.

The Clock Adjust screen should now appear. Follow the on screen prompts to update the time.

Pressing the Menu button at any time will exit the menu structure and return the user to the Main Screen.

2.3 SETTING THE CURRENT DATE

Press the "Menu" button on the front of the timer. The unit is now in "Menu Mode" and the screen should display the "CLOCK ADJUST" and "DATE ADJUST" options.

Use the UP and DOWN buttons to navigate through the options.

Press the ENTER button when the DATE ADJUST option is highlighted.

The Date Adjust screen should now appear. Follow the on screen prompts to update the date.

Pressing the Menu button at any time will exit the menu structure and return the user to the Main Screen.

2.4 AUDIO CONNECTIONS

Audio Output:

This output consists of stereo RCA sockets with an output of 0dBm into a 600Ω input. This is suitable for most PA amplifier auxiliary inputs.

Rear Panel Volume Controls:

The output levels of the Prebell, Bell and Music tones can all be adjusted via trimpots located on the rear of the unit.

2.5 DIP SWITCH SETTINGS

The A 4510B has optional settings which are set by the DIP switches on the rear of the unit.

IMPORTANT NOTE:
Ensure power is switched off when adjusting DIP switches.
New settings will be effective when power is switched back on.

Switch 1

This switch is used to loop the Bell tone, or play the Bell tone only once after it has been triggered. (Note: this affects only the automatic activation of the Bell tone. It does not apply to manual operation of the front Bell button).

OFF = Loop, ON = Play Once

Switch 2-4 Not Used.

2.6 24V OUTPUT CONNECTIONS

These contacts can be used for connection of override relays in remote volume controls, or for operating an external relay used to operate something like a school bell etc. (Note: These 24V DC outputs are limited to 120mA maximum current draw).

Prebell 24V Out:

These contacts are for switched 24V outputs whenever the Bell tone is activated. These may be used to run external systems such as override relays in remote volume controls.

When this output becomes active, 24V will appear between the N/O contact and the GND contact. When this output is not active 24V will appear between the N/C contact and the GND.

Music 24V Out:

These contacts are for switched 24V outputs whenever the Music tone is activated. These may be used to run external systems such as override relays in remote volume controls.

When this output becomes active, 24V will appear between the N/O contact and the GND contact. When this output is not active 24V will appear between the N/C contact and the GND.

Bell 24V Out:

These contacts are for switched 24V outputs whenever the Bell or Relay Only (No MP3 option) are activated. These contacts are for operating an external relay used to operate something like a lunch bell etc.

When this output becomes active, 24V will appear between the N/O contact and the GND contact. When this output is not active 24V will appear between the N/C contact and the GND.

Common 24V Out:

These contacts are for switched 24V outputs whenever the Bell, Prebell, Music or Relay Only (No MP3 option) tones are activated. When this output becomes active, 24V will appear between the N/O contact and the GND contact. When this output is not active 24V will appear between the N/C contact and the GND.

Relay Only 24V Out:

These contacts are for switched 24V outputs whenever the "Relay Only" option is activated. When this output becomes active, 24V will appear between the N/O contact and the GND contact. When this output is not active 24V will appear between the N/C contact and the GND.

A 4510B Yearly Timer with Network Access

2.7 BATTERY BACKUP (TIME)

On the rear of the unit is a switch labelled Battery Backup. This is used to backup the internal clock in the event of a power failure. The switch is set to OFF by default to ensure the backup battery isn't discharged.

(NOTE: this does not provide backup power to the unit itself. If a power fail backup supply is required this must be connected to the 24V DC input).

A power fail will not mean a loss of the programmed events, as they are stored on the Micro SD card. Once power is restored the unit will power up and read the events from the Micro SD card and operate as normal.

3.0 NETWORK ACCESS

The Redback® A 4510B has been upgraded from previous versions to now include access via a network connection. The unit is connected with the addition of the Redback® A 4498 Network Connection Pack. With the upgraded PC software all the event timing and audio file selection can be adjusted remotely.

Note: Audio files cannot be transferred via this connection. All audio files must be loaded onto the supplied Micro SD card via the PC software. These files are stored in a Library on the SD card and can then be selected remotely.

Figure 3 below demonstrates how to connect the timer to a network via the Redback® A 4498 Connection Pack. The pack includes a serial to ethernet converter, a propriety adaptor board, a DC power lead and a short CAT6 lead for connection between the A 4510B and the Adaptor board. The Serial to Ethernet Converter requires some configuration which is outlined in the A 4498 instruction manual.

Once the Serial To Ethernet Converter setup is complete and all required connections made, the unit should now be accessible via the PC software. Refer to the supplied Software Programming Guide for more information.

Note: An IT administrator or someone experienced with network protocols will be required to setup the network access.

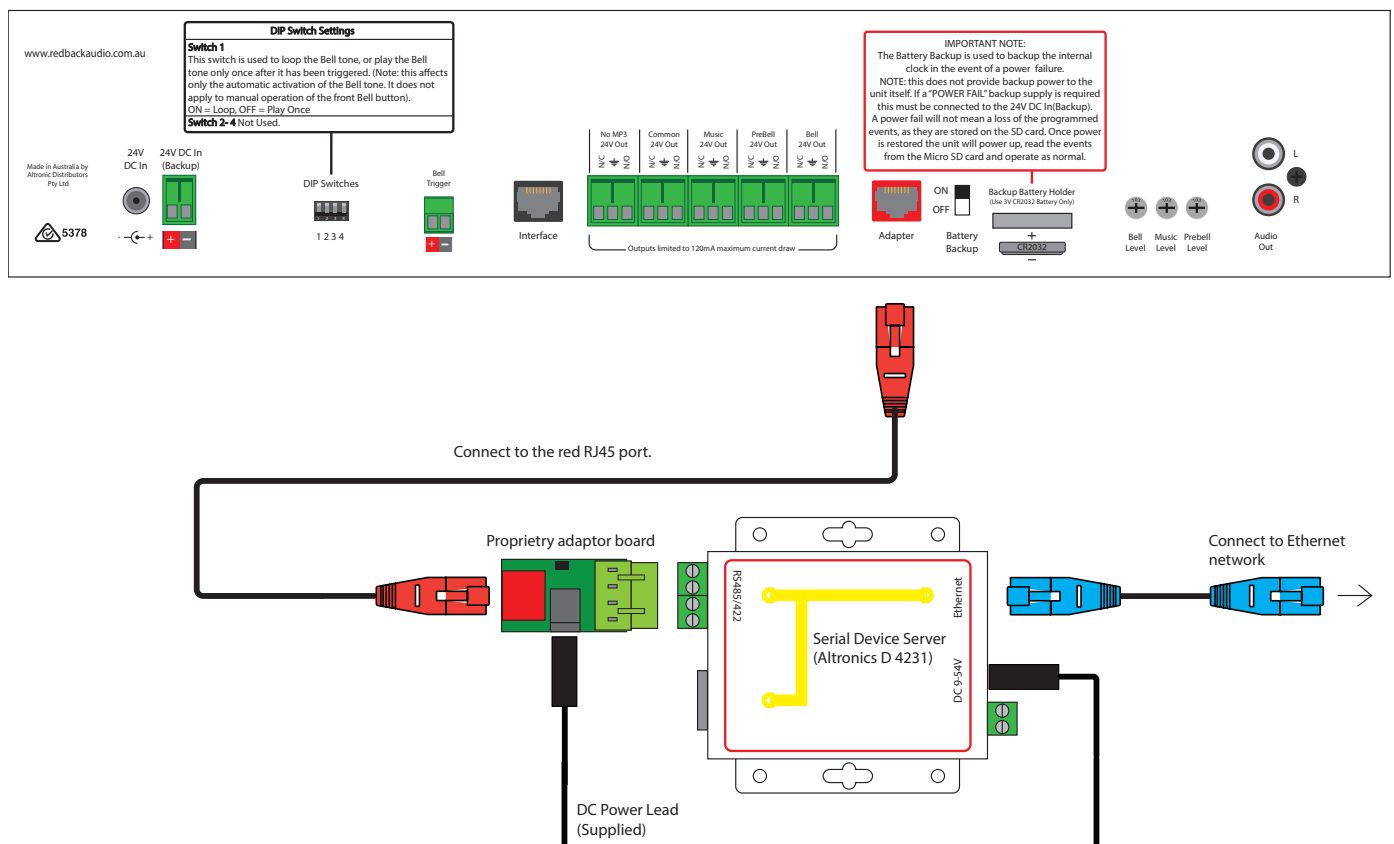

Fig 3

4.0 FIRMWARE UPDATES

It is possible to update the firmware for the A 4510B by downloading the latest update version from redbackaudio.com.au if available.

To perform an update, follow these steps.

- 1) Download the Zip file from the website.
- 2) Remove the Micro SD card from the rear of the A 4510B and insert it into your PC.
- 3) Extract the contents of the Zip file to the root folder of the Micro SD card.
- 4) Rename the extracted .BIN file to update.BIN.
- 5) Remove the Micro SD card from the PC following windows safe card removal procedures.
- 6) With the power lead removed from the rear of the unit, insert the Micro SD card back into the A 4510B.
- 7) Reconnect power to the A 4510B and turn ON. The unit will check the Micro SD card and if an update is required the A 4510B will perform the update automatically.

5.0 TROUBLE SHOOTING

5.1 SYMPTOMS AND REMEDIES

SYMPTOMS	REMEDIES
<i>SDCARD ERROR, Micro SD card NOT FOUND MESSAGE DISPLAYED</i>	CHECK Micro SD card HAS BEEN INSERTED CORRECTLY (see section 2.1 for more details)
<i>WINDOWS SOFTWARE WILL NOT RUN</i>	The Windows software for this product may not run on all Windows based devices. The .NET framework on the Windows device has to be updated to .NET Framework 4. Available for download on the microsoft website.
<i>MP3 ERROR MESSAGE ON STARTUP</i>	Check that audio files exist in the Bell, Prebell and Music Folders on the Micro SD card. (Note: The Bell folder must have only one MP3 file, Refer to section 2.1).
<i>CONFIG OR GROUP FOLDER ERROR MESSAGE ON STARTUP</i>	The Micro SD card must have the relevant CONFIG and GROUPS folders installed, and the configuration files must be in these folders. These are created by the Calendar Software Program. (Refer to section 2.1 and the "Software Programming Guide").

A 4510B Yearly Timer with Network Access

6.0 SPECIFICATIONS

OUTPUT LEVEL:.....0dBm

DISTORTION:.....0.01%

FREQ. RESPONSE:.....140Hz - 20kHz

OUTPUT CONNECTORS:

Audio Output:.....RCA Stereo Socket

Common 24V DC Out:.....Screw Terminals

Pre Bell 24V DC Out :..... Screw Terminals

Bell 24V DC Out:.....Screw Terminals

Music 24V DC Out:.....Screw Terminals

No MP3 DC Out:.....Screw Terminals

PLEASE NOTE: 24V DC Output loads limited to
0.12Amp each

INPUT CONNECTORS:

24V DC Power:.....Screw Terminals

24V DC Power:.....2.1mm DC Jack

Bell Trigger: Screw Terminals

CONTROLS:

Bell:.....Rear Volume

Prebell:.....Rear Volume

Music:.....Rear Volume

Power:.....On/Off Switch

Bell Switch:..... Push Switch

Isolate Switch:..... Push Switch

INDICATORS:..... Power on, MP3 error

MP3 FILE FORMAT: up to 320kbps, 44.1kHz,
32bit, VBR or CBR, Stereo (even better as mono).

POWER SUPPLY:..... 24V DC @ 1 Amp

DIMENSIONS:≈..... 482W x 180D x 88H

WEIGHT: ≈..... 2.8 kg

COLOUR:Black

* Specifications subject to change without notice