

Operating Manual A 4567C 10 Zone Line Monitoring Unit

Optional Accessories



Redback® Proudly Made In Australia

IMPORTANT NOTE:

Please read these instructions carefully from front to back prior to installation. They include important setup instructions. Failure to follow these instructions may prevent the amplifier from working as designed.



REDBACK

You may be surprised to learn that Redback is still manufacturing hundreds of product lines right here in Australia. We have resisted the move offshore by offering our customers better quality products with innovations to save them time and money.

Our Balcatta production facility manufactures/assembles:

Redback public address products
One-shot speaker & grill combinations
Zip-Rack 19 inch rack frame products

We strive to support local suppliers wherever possible in our supply chain, helping to support Australia's manufacturing industry.

Redback Audio Products

100% developed, designed & assembled in Australia.

Since 1976 we have been manufacturing Redback amplifiers in Perth, Western Australia. With over 40 years experience in the commercial audio industry, we offer consultants, installers and end users reliable products of high build quality with local product support. We believe there is significant added value for customers when purchasing an Australian made Redback amplifier or PA product.

Local support & feedback.

Our best product features come as a direct result of feedback from our customers, and when you call us, you speak to a real person - no recorded messages, call centres or automated push button options.

It's not only the assembly team at Redback who are employed as a direct result of your purchase, but hundreds more at local companies used in the supply chain.

Industry leading 10 year warranty.

There's a reason we have the industry leading DECADE warranty. It's because of a long tried and tested history of bullet-proof reliability. We've heard PA contractors tell us they still see the original Redford amplifier still in service in schools.

We offer this comprehensive parts & labour warranty on almost every Australian Made Redback public address product. This offers both installers and end users peace of mind that they will receive prompt local servicing in the rare event of any problems.

1.1 INTRODUCTION

Specifically designed to monitor the condition of 100V line speaker systems in emergency paging and fire evacuation installations. Many large commercial installations have speaker circuits in excess of 250W. Traditional line monitoring units were limited to 50W per zone and would not handle this load. The A 4567C can handle loads up to 500W per zone. The microprocessor controlled circuit continuously monitors loudspeaker lines for normal, open or short circuit condition. A multi-colour LED indicates line condition accordingly for each zone. Internal audible alarm buzzer with cancel button is fitted. With any fault condition, a switched output is provided for remote monitoring purposes. This is a switched to ground signal. Three outputs are supplied. One for short circuit conditions. One for an open circuit fault. Plus a combined output for any fault condition. The system can be configured to operate with multiple amplifiers

1.2 FEATURES

- Monitors 10 zones @ 500W max per zone
- Monitors normal, open and short circuit conditions
- Switched output for remote monitoring
- Pluggable terminals for all connections
- 10 Year Warranty
- Australian Designed and Manufactured

1.3 WHAT'S IN THE BOX

A 4567C Line Monitoring Unit
 MA8241 24V 1A plugpack
 Instruction Booklet

1.4 FRONT PANEL GUIDE

Figure 1 shows the layout of the A 4567C front panel.

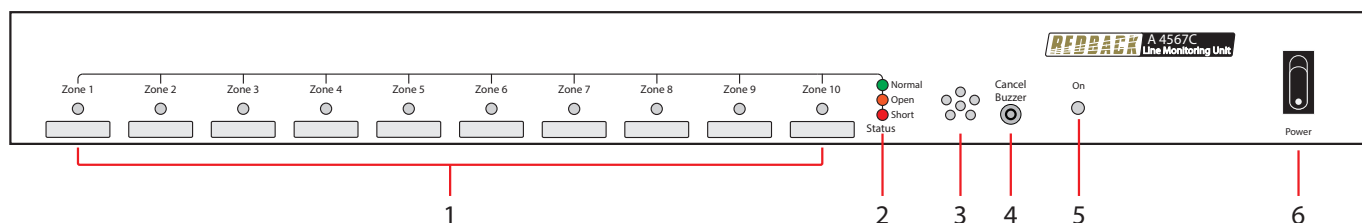

Fig 1

- 1 Zone Indicators**
 These LED's indicate the status of each of the 10 zones.
- 2 Zone Status Indicator Legend**
 The legend outlines the status of the 10 zones. Green indicates a "Normal" condition on the zone. Orange indicates an "Open" condition on the zone. i.e. the speaker line has a break somewhere on the line. Red indicates a "Short" condition. i.e. there is a short circuit on the line.
- 3 Buzzer**
 The buzzer sounds when either an "Open" or a "Short" condition occurs on a zone.
- 4 Cancel Buzzer Button**
 This button is used to cancel the buzzer from sounding. Note: This does not turn off the fault indicator/s.
- 5 On indicator**
 Indicates when the unit has power.
- 6 Power Switch**
 Used to turn on the unit. Note: The 24V DC backup input bypasses the power switch.

1.5 REAR PANEL CONNECTIONS

Figure 2 shows the layout of the A 4567C rear panel.

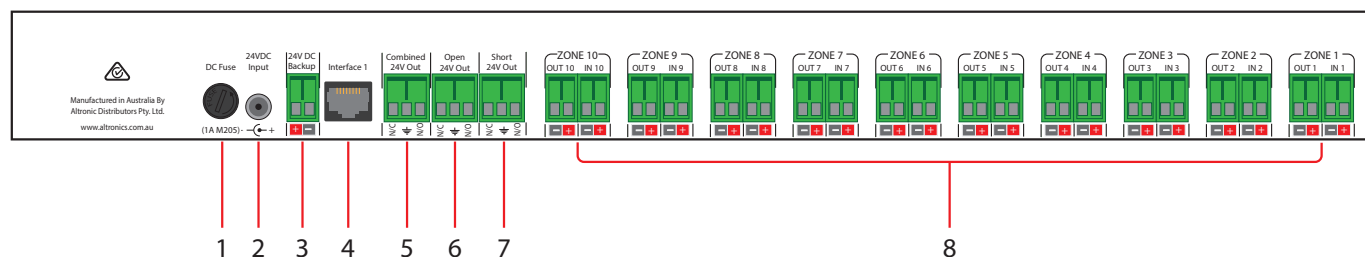

Fig 2

- 1 DC Fuse (1A M205)**
This fuse protects the internal power supply. Replace with M205 1A rated fuse only.
- 2 24V DC Input (Main Supply)**
Connects to a 24V DC supply with at least 1 amp current capacity. (Please observe the polarity)
- 3 24V DC Input (Backup)**
Connects to a 24V DC backup supply with at least 1amp current capacity. (Please observe the polarity)
- 4 Interface**
This connection is to interface to the optional A 4568 Fire Board Interface.
- 5 Combined 24V DC Output**
This is a combined 24V DC output which is activated when any fault is active. i.e. An "Open" or "Short" condition on any zone. The terminals provided can be used for "Normal" or "Failsafe" modes. The output terminals have a N/O (normally open), N/C (normally closed) and a ground connection. In this configuration 24V appears between the N/O and ground terminals when this output is activated. When this output is not active 24V appears between the N/C and ground terminals.
- 6 Open 24V Output**
This is a 24V DC output which is activated when any zone goes into an "Open" fault condition. The terminals provided can be used for "Normal" or "Failsafe" modes. The output terminals have a N/O (normally open), N/C (normally closed) and a ground connection. In this configuration 24V appears between the N/O and ground terminals when this output is activated. When this output is not active 24V appears between the N/C and ground terminals.
- 7 Short 24V Output**
This is a 24V DC output which is activated when any zone goes into a "Short" fault condition. The terminals provided can be used for "Normal" or "Failsafe" modes. The output terminals have a N/O (normally open), N/C (normally closed) and a ground connection. In this configuration 24V appears between the N/O and ground terminals when this output is activated. When this output is not active 24V appears between the N/C and ground terminals.
- 8 Zone Connections**
These screw terminals are used to connect the 10 zones to their associated Amplifiers and Speaker Loads. The "IN" terminals are connected to the amplifiers and the "OUT" terminals are connected to the speaker lines.
NOTE : Speakers on any zone must be wired in a "Loop In", "Loop Out" (or parallel) configuration. "Star" wiring or "Tee Offs" are not permitted and will cause the system to go register a fault. See Fig 2.2 for more details.
Any unused zones must have a 100KΩ 0.25W end of line resistor fitted.

2.1 Installing the A 4567C Line Monitoring Unit (LMU)

The A 4567C is a Line Monitoring unit or LMU. A LMU monitors the condition of 100V PA speaker lines and alerts the user when there is a problem with the speaker line wiring.

The unit is powered by the supplied 24V DC 1 amp plugpack which is connected to the 24V DC, 2.1mm Input Jack. If a backup power supply is required, this is connected to the screw terminals marked 24V DC Backup as shown in Figure 3. Up to 10 zones can be monitored and each zone has a LED indicator which indicates the condition of the zones' speaker line. The output of the 100V Amplifiers are connected to the inputs on the rear of the A 4567C. All of the inputs are isolated from each other so up to 10 amplifiers can be used or any combination below that number. e.g. One amplifier connected to 2 or more inputs. NOTE : Never connect 2 or more amplifiers to one zone as it will cause damage to the A 4567C and the amplifiers.

The output terminals of the A 4567C are connected to the speaker lines. A maximum of 500 Watts of load per zone is allowed, any more than this will damage the A 4567C. Any number of 100V line transformer/speaker combinations can be used as long as the total load for each zone is below 500 Watts.

Figure 3 Illustrates how to connect the A 4567C. For the purposes of this example only zones 4 and 5 are shown connected to amplifiers and speaker loads. One amplifier has been used to supply the audio to both zones, which is output from the 100V output of the amplifier. There are many configurations available, one amplifier could be used for each zone requiring 10 amplifiers or multiple zones could be connected to the same amplifier.

NOTE: Never connect two or more amplifiers to the same zone.

The speaker lines connected to output zone 4 and output zone 5, must be fitted with 100KΩ resistors at the end of the lines and all speakers must have 22uF Bipolar caps fitted. See Figure 4 for more details. NOTE : The maximum wire run is 200 metres.

An A 4568 Fire Indicator Board Interface has been connected to the A 4567C via a Cat5e cable. The A 4568 has closing contact outputs which are triggered when it receives fault information from the A 4567C. These closing contacts are suitable for use on Fire Indicator Boards (FIB's).

The Combined 24V Out N/O contacts have been connected to the A 4576 Alarm Wallplate. When any fault condition occurs on any zone of the A 4567C, 24 volts will become present at the Combined 24V Out N/O contacts and trigger the A 4576 Alarm wallplate.

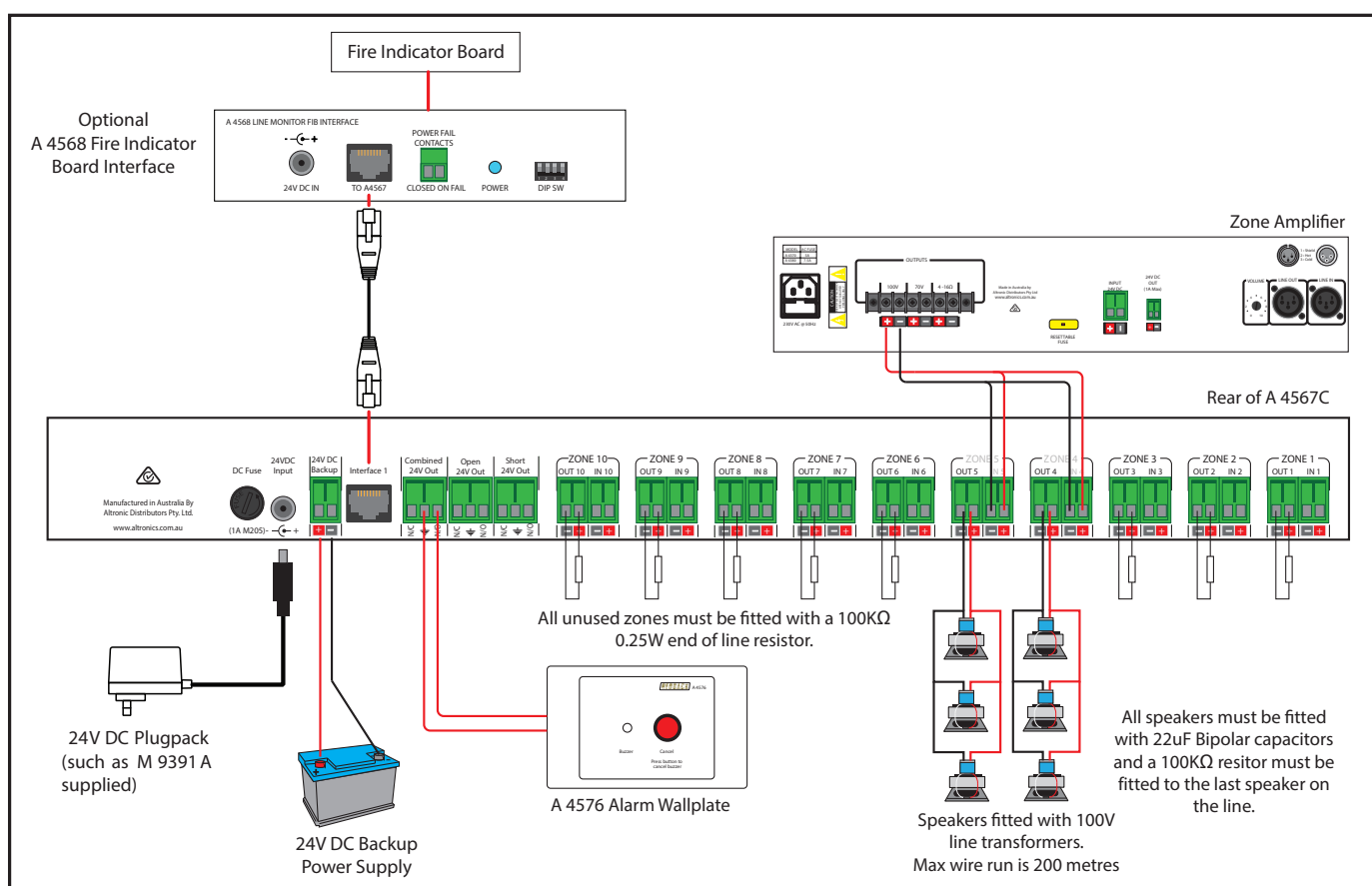

Fig 3

2.2 Configuring the speaker lines for monitoring.

As mentioned in section 2.1 all the speaker lines must be of the 100V type, with all speakers fitted with a 22uF Bipolar capacitor and all lines terminated with an 100KΩ resistor of at least 0.25W rating. Figures 4a - 4d illustrate the requirements for the speaker lines.

Figure 4a shows an C 2168C 100mm ceiling speaker fitted with the latest in EWIS requirements.

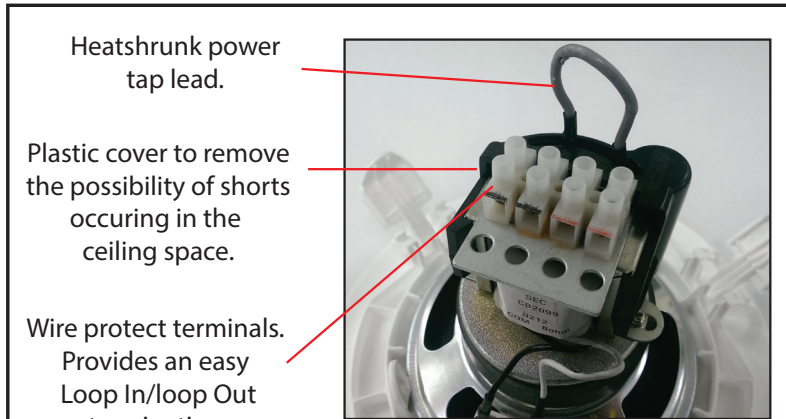

Fig 4a

Figure 4b shows the 22uF Bipolar capacitor visible as the plastic cover has been removed from the transformer. The various transformer power taps are also visible. This model has wattages ranging from 0.33W to 5W. If this speaker was wired in parallel to 99 other speakers, all on the 5W tap, this would give a total of 500 watts for the speaker line which is the maximum load for a zone on the A 4567C.

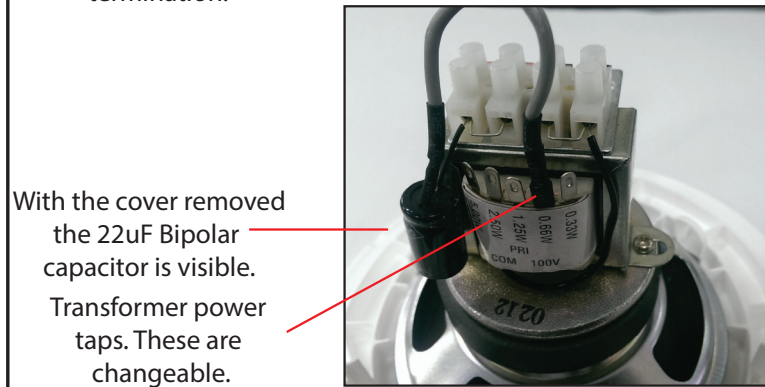

Fig 4b

Figure 4c shows the Loop In/ Loop Out wiring configuration required when wiring up multiple speakers on a line.

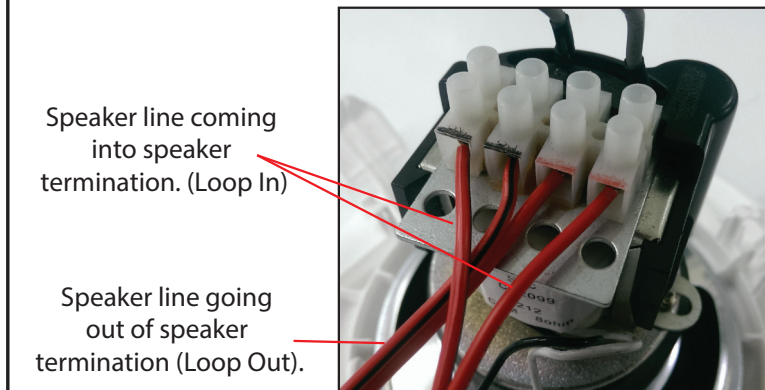

Fig 4c

Figure 4d shows the end of line resistor fitted to the last speaker in the line. The value must be 100KΩ with a power rating of at least 0.25 watts.

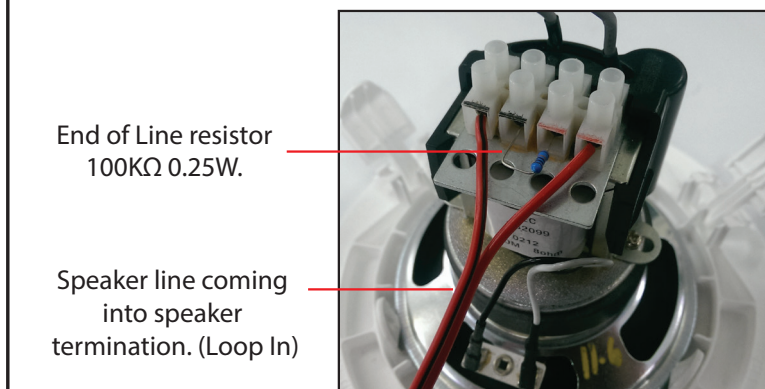

Fig 4d

2.3 Monitoring the Faults

When the A 4567C is switched on the unit will pause for about 10 seconds to allow the protected zones to be checked for their condition.

If there are no faults with any of the speaker lines then all the LED's should be green. If a fault is found on any of the zones the buzzer will sound and the "Cancel" switch LED will flash. The faults on the lines can either be a "Short" signified by a red LED on the zone with the fault, or an "Open" circuit condition signified by an orange LED on the zone with the fault.

To cancel the buzzer simply press the "Cancel" switch. NOTE : The fault indicators will remain on after the buzzer is cancelled.

Any new fault conditions will result in the alarm tone sounding again and the "Cancel" switch LED to illuminate. From then on, no matter how many times the cancel button is pushed the A 4567C will go into alarm mode any time there is a new fault condition on any of the zones.

The alarm will not sound again if a zone goes from a fault condition to good condition.

2.4 Remote Monitoring Of Faults

The fault status of the zones can be monitored remotely by connecting an external buzzer or warning light to the 24V DC switched outputs. Other options for remote monitoring include using external relay boards such as the S 4444 24V relay board or the S 4455 DIN rail relay box. These would be suitable for connection to a Fire Indicator Board which requires voltage free closing contacts for triggering.

There are three sets of 24V DC switched output terminals available on the rear of the A 4567C.

Combined 24V DC Output:

The first is a combined 24V DC output which is activated when any fault is active. i.e. An "Open" or "Short" condition on any zone. The terminals provided can be used for "Normal" or "Failsafe" modes. The output terminals have a N/O (normally open), N/C (normally closed) and a ground connection. In this configuration 24V appears between the N/O and ground terminals when this output is activated. When this output is not active 24V appears between the N/C and ground terminals.

Open 24V Output:

This is a 24V DC output which is activated when any zone goes into an "Open" fault condition. The terminals provided can be used for "Normal" or "Failsafe" modes. The output terminals have a N/O (normally open), N/C (normally closed) and a ground connection. In this configuration 24V appears between the N/O and ground terminals when this output is activated. When this output is not active 24V appears between the N/C and ground terminals.

Short 24V Out

This is a 24V DC output which is activated when any zone goes into a "Short" fault condition. The terminals provided can be used for "Normal" or "Failsafe" modes. The output terminals have a N/O (normally open), N/C (normally closed) and a ground connection. In this configuration 24V appears between the N/O and ground terminals when this output is activated. When this output is not active 24V appears between the N/C and ground terminals.

The A 4567C can be connected to an External Indicator Board by using the optional A 4568 Interface Box. This interface box has ten voltage free, closing contact outputs suitable for triggering an external indicator board. The A 4568 is connected to the A 4567C via a CAT5e cable as shown in Fig 3.

The A 4567C can also be remotely monitored using the A4576 wall plate, which could be connected to the combined 24 V switched output of the A 4567C as shown in Fig 3. Whenever any fault condition occurs 24V will become active from these terminals and will trigger the buzzer on the wall plate. NOTE : Cancelling the buzzer on the wall plate does not cancel the buzzer on the A 4567C LMU.

3.1 SYMPTOMS AND REMEDIES

SYMPTOMS	REMEDIES
No power to unit.	Check fuse and replace with M205 type 1A fuse if required.
The "SHORT" LED comes up on a zone.	Check that the 100KΩ EOL resistor is fitted to the end of the line and that 22uF BP capacitors are fitted to all speakers. If they are fitted there must be a short across the line.
The "OPEN" LED comes up on a zone.	Check that the 100KΩ EOL resistor is fitted to the end of the line and that 22uF BP capacitors are fitted to all speakers. If they are fitted there must be a break in the line.

4.1 SPECIFICATIONS

OUTPUT CONNECTORS:

Open 24V DC Out:..... Screw Terminals
 Short 24V DC Out:.....Screw Terminals
 Combined 24V DC Out:.....Screw Terminals

INPUT CONNECTORS:

24V DC Power:.....Screw Terminals
 Zone connections:.....Screw Terminals

CONTROLS:

Cancel Switch:.....Push Switch

INDICATORS:.....Power on, Zone fault condition

POWER SUPPLY:..... 24V DC

DIMENSIONS:≈..... 483W x 177D x 44H

WEIGHT: ≈..... 3.7 kg

COLOUR:Black

* Specifications subject to change without notice