

Operating Manual

A 4574 ALERT/EVAC/CHIME TONE GENERATOR

A 2078B Alert/Evac/Cancel Remote Wallplate

A 2081 Alert/Evac/Chime/Cancel Remote Wallplate

Optional Accessories

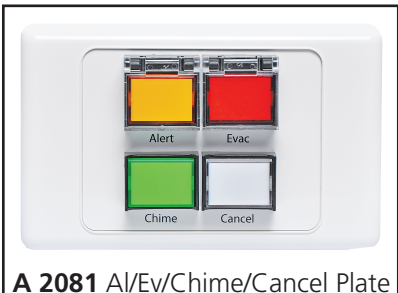
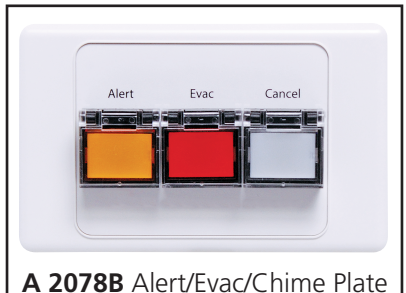

IMPORTANT NOTE:

Please read these instructions carefully from front to back prior to installation. They include important setup instructions. Failure to follow these instructions may prevent the unit from working as designed.

Redback® A 4574 Alert/Evac/Chime Tone Generator

1.0 Overview

This unit has provision for playback of Alert, Evacuation and chime tones as well as an alert and/or emergency message. When connected to a paging system amplifier, building occupants can be alerted and/or evacuated in the event of an emergency e.g.: fire, gas leak, bomb scare, earthquake.

The Alert, Evacuation, Bell, and Emergency Messages are all MP3 based and stored on a Micro SD card which is accessible from the front of the unit. The Alert, Evacuation and bell tones and cancel function are triggered by the front switches, or by the rear terminal contacts for remote activation i.e. a clock, remote switch or optional A 2078B and A 2081 remote wall plates.

It features 24V DC switched outputs which are enabled when the Alert, Evac or Chime tones are triggered. It is powered from a 24V DC source (plugpack supplied) and features a line out facility and MP3 based Message Voice Over.

2.0 Features

- Level controls for alert/evac, bell and voice over
- Front panel alert/evac/bell and cancel switches
- All tones MP3 based
- Alert/Evac Emergency tones can be configured for momentary or continuous operation
- 1U half rack cabinet
- Alert and Evac Tones conform to AS 1670.4 (Library included on Micro SD card)
- Compatible with fire indicator boards & break glass alarms
- Remote operation of alert , evac, bell tones & cancel.
- Local operation of alert, evac and bell
- MP3 based Alert and Evacuation Voice over message facility
- Bell chime facility
- Switched 24V DC outputs for override relays or strobes (outputs limited to 120mA)
- On-board timer for remote alert activation adjustable from 30secs to 7.5min in 30 second increments. Switches from alert to evac after preset time.
- Auxiliary level output
- 10 year warranty
- Australian designed and manufactured

3.0 Front Panel Guide

The layout of the A 4574 front panel is shown below in figure 1.

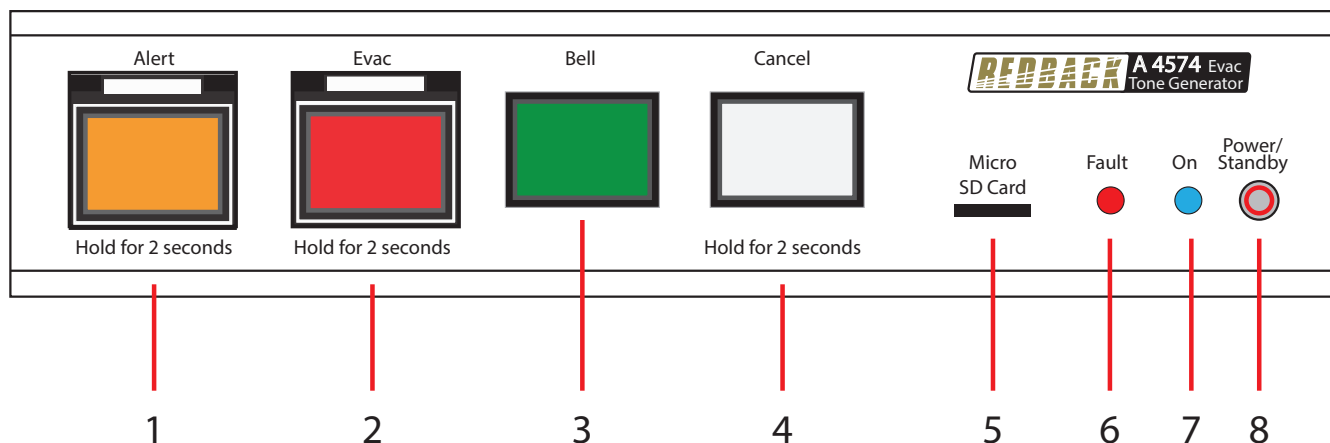

Fig 1.

- 1 Alert Tone Activation Switch**
This switch is used to activate the Alert tone. Press for 2 seconds to activate.
- 2 Evac Tone Activation Switch**
This switch is used to activate the Evacuation tone. Press for 2 seconds to activate.
- 3 Bell Tone Activation Switch**
This switch is used to activate the Bell tone.
- 4 Cancel Tone Activation Switch**
This switch is used to cancel the Alert, Evac or Bell tones. Press for 2 seconds to activate.
- 5 Micro SD Card**
This is used to store the MP3 audio files for the Alert, Evac, Bell and Message playback.
- 6 Fault Indicator**
This LED will illuminate when the unit has trouble reading an MP3 file or if files are missing from the Micro SD card..
- 7 On Indicator**
This LED indicates the unit has power.
- 8 Standby Switch**
When the unit is in standby mode this switch will illuminate. Press this button to switch the unit ON. Once the unit is ON the On indicator will illuminate. Press this switch again to put the unit back in standby mode.

4.0 Rear Panel Guide

The layout of the A 4574 front panel is shown below in figure 2.

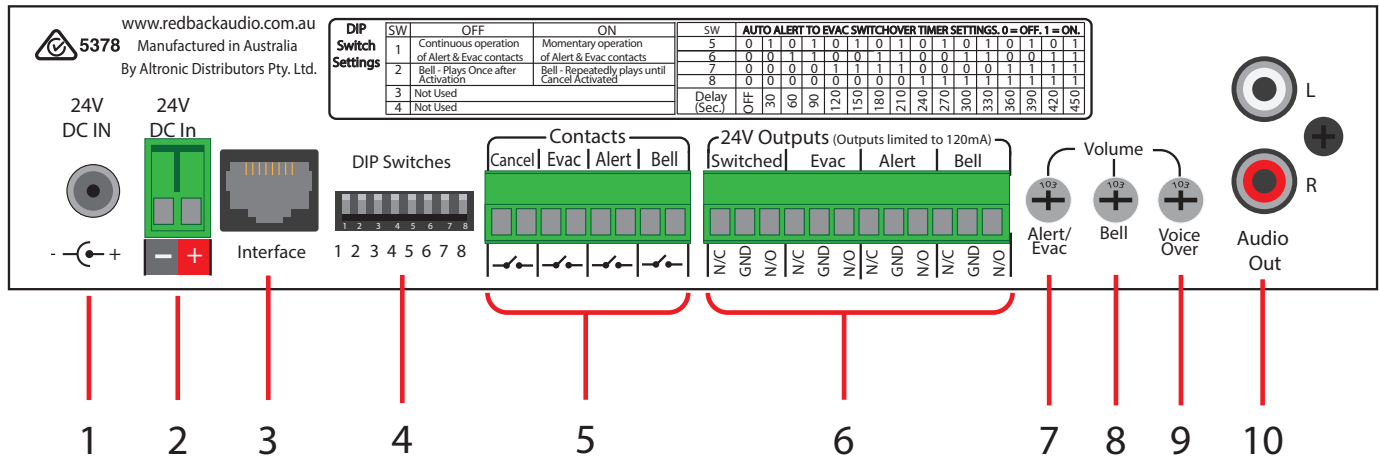

Fig 2.

- 1 **24V DC input**
Connects to a 24V DC Plugpack with 2.1mm Jack.
- 2 **24V DC Input (Backup)**
Connects to a 24V DC backup supply with at least 1 amp current capacity. (Please observe the polarity)
- 3 **RJ45 interface**
This RJ45 port is for connection to future peripherals.
- 4 **Dip Switches**
These are used to select various options. Refer to DIP Switch Settings section 7.0.
- 5 **Contacts**
These contacts are for remote triggering of the Alert, Evac, Bell and cancel functions. These could be triggered by a remote switch or any other closing contact.
- 6 **24V DC Switched Outputs (Limited to 120mA current draw)**
Switched 24V Out
This is a common 24V DC output which is activated when any of the Bell, Alert or Evac tones are triggered. The terminals provided can be used for "Normal" or "Failsafe" modes (see section 8.0 for more details).
Evac 24V Out
This is a 24V DC output which is activated when the Evac tone is activated. The terminals provided can be used for "Normal" or "Failsafe" modes (see section 8.0 for more details).
Alert 24V Out
This is a 24V DC output which is activated when the Alert tone is activated. The terminals provided can be used for "Normal" or "Failsafe" modes (see section 8.0 for more details).
Bell 24V Out
This is a 24V DC output which is activated when the Bell tone is activated. The terminals provided can be used for "Normal" or "Failsafe" modes (see section 8.0 for more details).
- 7 **Alert/Evac Volume**
Adjust this trimpot to adjust the Alert and Evacuation tones playback volume.
- 8 **Bell Volume**
Adjust this trimpot to adjust the Bell playback volume.
- 9 **Voice-over Volume**
Adjust this trimpot to adjust the message playback volume.
- 10 **Audio Out RCA Connectors**
Connect these outputs to the input of the PA amplifier.

Redback® A 4574 Alert/Evac/Chime Tone Generator

5.0 Alert, Evac and Bell switches

The Alert, Evac and Bell switches on the front of the unit all work in momentary mode. ie. The alert tone will continue to sound after the alert switch is momentarily pressed and the evac tone will continue to sound after the evac switch is momentarily pressed. *Note: There is no automatic alert to evac switch-over option associated with the front panel switches.*

Note 1: The tone that is being sounded (ie alert, evac, bell) will be indicated by the illumination of the relevant front panel indicator.

Note 2: To cancel a tone either use the remote cancel contacts or the front cancel button. Note the cancel button will need to be depressed for 2 seconds. This is to prevent accidental cancelling of a tone.

The Alert, Evac and Bell tones are stored on the supplied SD card. Separate folders are supplied on the SD card for each tone. It is up to the user to provide the MP3 files (they must be in MP3 format) for each of the tones. A library of sample MP3 files is supplied (in the #LIBRARY# folder). See section 11.0 for more details.

NOTE: The Fault LED will flash if any of the folders on the SD card are left empty. I.e. the Alert, Evac or Bell must all have an MP3 file inside.

Once these Alert, Evac and Bell outputs are activated, the corresponding 24V switched outputs will become active (refer to section 8.0 for more details).

6.0 Remote Contacts (Rear of unit)

Provision has been made for four remote contacts on the back of the unit. These are all activated by closing the corresponding contact (connecting the terminals together).

The alert, evac, bell and cancel remote contacts can be triggered with any sort of closing contact such as a timer to trigger the bell, a remote switch or optional A 2078B and A 2081 remote wall plates (see section 12.0 for A 2078B and A 2081 wiring details).

Alert contact: These contacts are for remote triggering of the alert tone ie: for use with Fire Indicator Boards, break glass alarms etc. These contacts can be set to either continuous or momentary operation via dip switch 1. (refer to section 7.0). In continuous mode the alert tone will continue while the alert contact is triggered.

In momentary mode the alert tone will continue to sound after a momentary trigger of the alert contact.

Evac Contact: These contacts are for remote triggering of the evac tone. Connecting these terminals together will activate the evac tone. These contacts can be set to either continuous or momentary operation via dip switch 1. (refer to section 7.0). In continuous mode the evacuation tone will continue while the evac contact is triggered.

In momentary mode the evacuation tone will continue to sound after a momentary trigger of the evac contact.

Bell Chime Contacts: These contacts are for remote triggering of the bell chime sound. This bell chime can be used for signalling lunch breaks, start of classes, and can be triggered from a time clock or similar device.

Cancel contact: These contacts are for remote cancelling of the alert or evac tones.

7.0 Dip Switch Settings

The A 4574 has various options which are set by the DIP switches on the rear of the unit which are outlined below.

IMPORTANT NOTE:
Ensure power is switched off when adjusting DIP switches.
New settings will be effective when power is switched back on.

Switch 1: The Alert and Evac contacts can be set to either continuous or momentary operation.

In continuous mode the alert/evac tone will continue while the corresponding rear contact is triggered.

In momentary mode the alert/evac tone will continue to sound after a momentary trigger of the rear contact.

1 - OFF: continuous operation of alert/evac contacts

1 - ON: momentary operation of alert/evac contacts

Switch 2: This switch is used to either loop the Bell, or play the Bell only once after it has been triggered.

2 - OFF: Bell MP3 will play once

2 - ON: Bell MP3 loops

Switches 5 - 8 Evacuation Timer Settings:

These switches control the time period before the unit switches from the alert, to the evac tone when the Alert is triggered by the rear contact. This time period can be switched from 30s to 7.5 minutes in 30s increments. Factory preset is 30s.

Note: Setting all switches 5 - 8 to OFF deactivates the switchover function.

Alert -Evac Timer Settings

Time (sec)	DIP switch			
	5	6	7	8
30	on	off	off	off
60	off	on	off	off
90	on	on	off	off
120	off	off	on	off
150	on	off	on	off
180	off	on	on	off
210	on	on	on	off
240	off	off	off	on
270	on	off	off	on
300	off	on	off	on
330	on	on	off	on
360	off	off	on	on
390	on	off	on	on
420	off	on	on	on
450	on	on	on	on

Redback® A 4574 Alert/Evac/Chime Tone Generator

8.0 24V OUTPUT CONNECTIONS

The A 4574 is fitted with four sets of 24V switched outputs for driving external devices such as strobes, sirens and attenuators. Each output has a maximum current draw of 120mA. When connecting devices which require more than 24V DC @ 120mA then an external supply and relays will be required.

In the illustration of figure 3 a high current school bell is to be activated by the Bell 24V switched output. As the current draw of the Bell is more than 120mA, a relay board is used to switch an external power supply. The Redback S 4444 24V Relay Board as shown is an inexpensive and easily installed option designed for this purpose. 24V DC strobes such as the Redback S 5423, S 5430 and S 5435 strobes also draw more than 120mA so they are connected in the same fashion as shown in figure 3.

Switched 24V Out:

These contacts are for connection of override relays in remote volume controls. An override relay is necessary where attenuators are used so that the alert tone, evac tone or message is broadcast at full volume regardless of the volume setting on the individual volume control (attenuator).

The override relay can be set to "NORMAL" mode when connection is made between the N/O (normally open) contact and the GND connection. In this configuration 24V appears when any of the alert tone, evac tone, voice over message or paging functions are activated.

The override relay can be set to "FAILSAFE" mode when connection is made between the N/C (normally closed) contact and the GND connection. In this configuration 24V is removed when any of the alert tone, evac tone, voice over message or paging functions are activated.

Alert 24V Out:

These contacts are for switched 24V outputs whenever the alert tones is activated. This may be used to run external systems such as strobes in unusually noisy environments. These operate in the same manner as the switched 24V out contacts i.e. connection between the N/O contact and the GND contact will operate in NORMAL mode and connection between the N/C contact and the GND will operate in FAILSAFE mode.

Evac 24V Out:

These contacts are for switched 24V outputs whenever the evac tones is activated. This may be used to run external systems such as strobes in unusually noisy environments. These operate in the same manner as the switched 24V out contacts i.e. connection between the N/O contact and the GND contact will operate in NORMAL mode and connection between the N/C contact and the GND will operate in FAILSAFE mode.

Bell 24V Out:

These contacts are for operating an external relay used to operate something like a lunch bell etc.

These operate in the same manner as the switched 24V out contacts i.e.: connection between the N/O contact and the GND contact will operate in NORMAL mode and connection between the N/C contact and GND will operate in FAILSAFE mode.

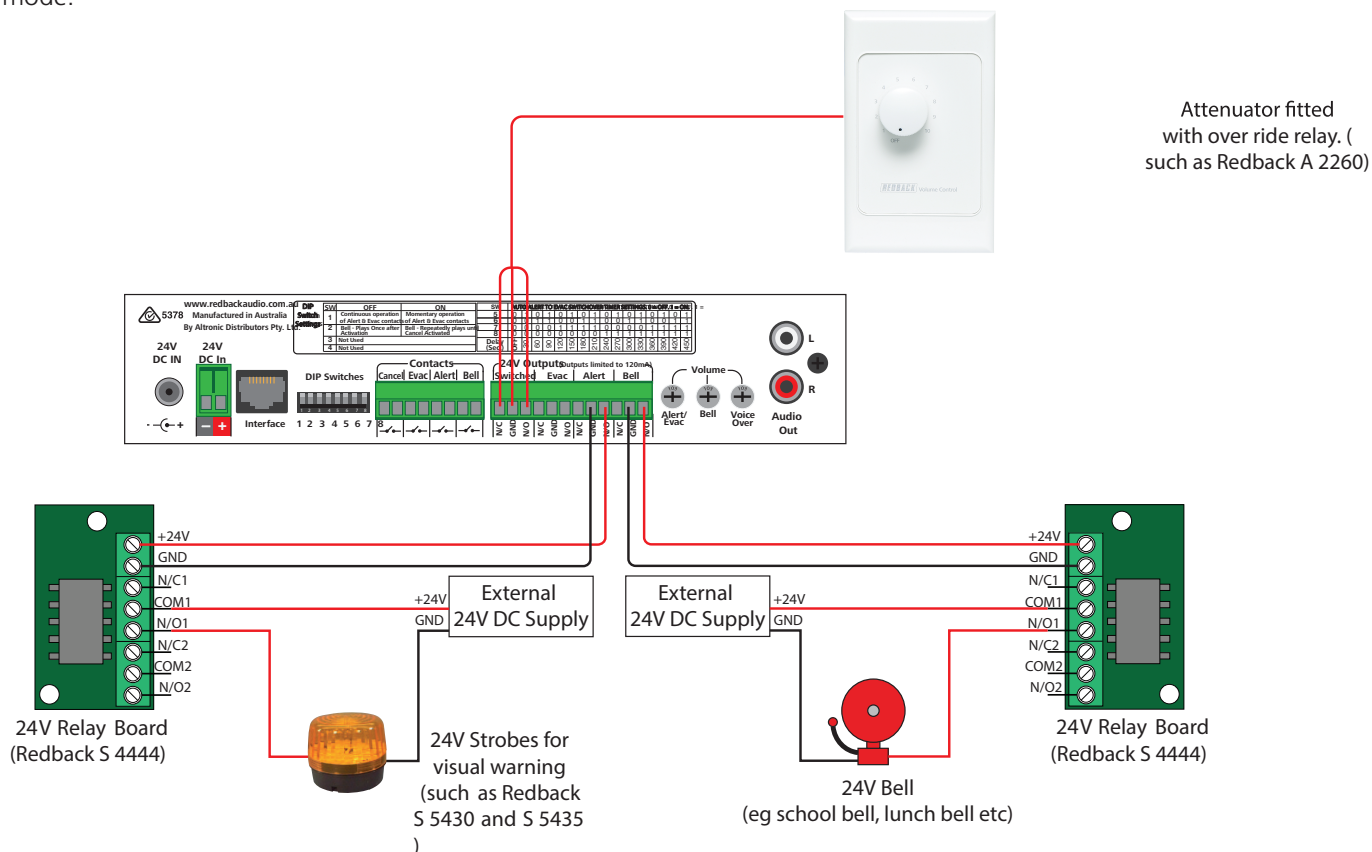

Fig 3.

Redback® A 4574 Alert/Evac/Chime Tone Generator

9.0 MP3 AUDIO FILES and ALERT and EVAC VOICE OVER MESSAGES

The supplied Micro SD card houses all the MP3 audio files used for the output tones. These files are stored in six separate folders (see figure 4) and relate to the corresponding output. e.g. the Alert folder houses the MP3 file to be played when the Alert mode is triggered.

These files can be any length and bit rate, but must be in MP3 format (they cannot be Wav files or AAC files).

(NOTE: only one MP3 file can be in each folder).

There is also a folder labelled "#LIBRARY#" which contains a host of sample MP3 files.

The "Voice" folder contains the MP3 audio files played as the Alert and Evacuation messages. There are separate folders for both the Alert and Evac messages as shown in figure 4.

The messages have to be recorded in MP3 format using any readily available PC software or other means, and then transferred to these folders.

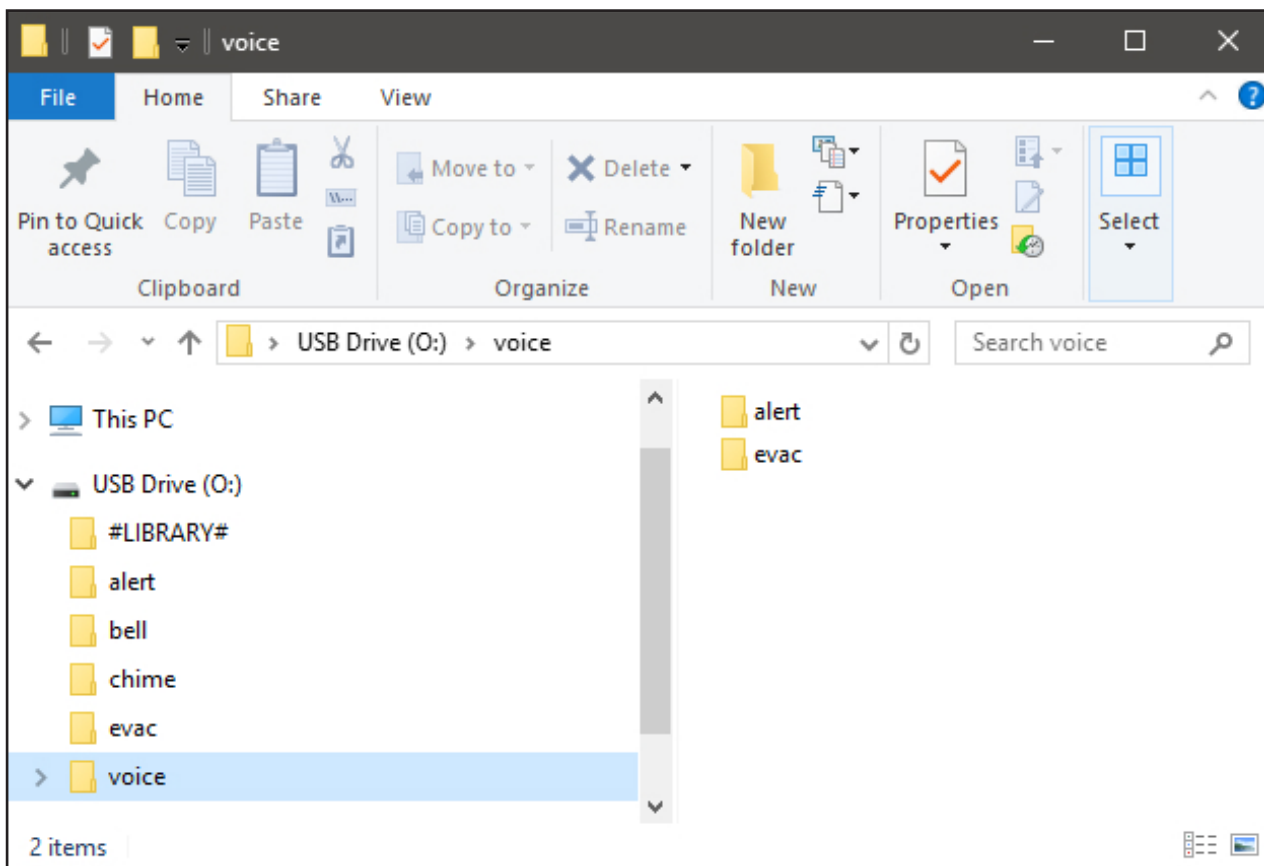

Fig 4.

10.0 Activating the Voice Over Message:

Voice over messages become active when an MP3 file is present in the relevant folder.

If the voice over message is not required leave the folder empty.

11.0 Installing MP3 Files

You will first need to remove power from the A 4574 then remove the Micro SD card from the front of the unit.

To remove the Micro SD card, push the card in and it will eject itself.

In order to access the program, the Micro SD card will need to be connected to a PC. You will need a PC or laptop equipped with a Micro SD card reader to do this. If a Micro SD slot is not available then the Redback D 0371A USB Memory Card Reader or similar would be suitable (not supplied).

Step by step guide to installing an MP3 onto the Micro SD card with a Windows installed PC

Make sure the PC is on and card reader connected and correctly installed. Then insert the Micro SD card into the reader. Go to "My Computer" or "This PC" and open the Micro SD card which is usually marked "Removable disk" or "USB Drive".

In this case it is named "USB Drive (O:)" as shown in figure 5.

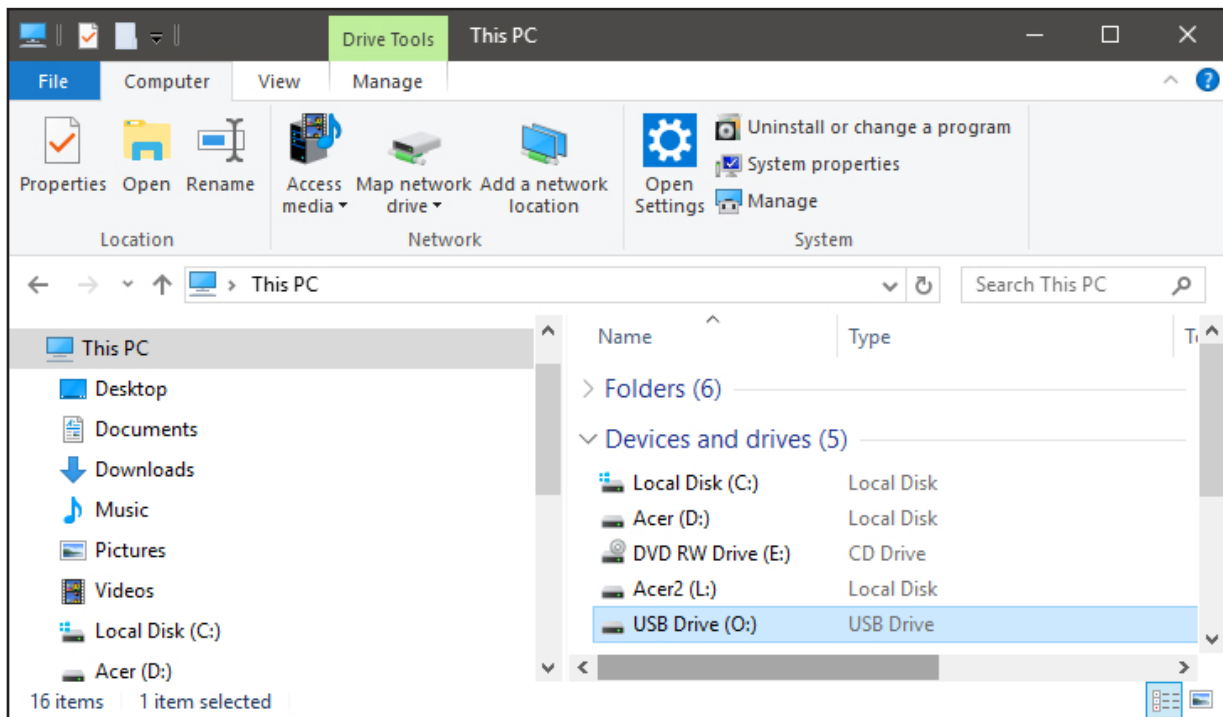

Fig 5

Open the USB Drive and you should get a window that looks like figure 6.

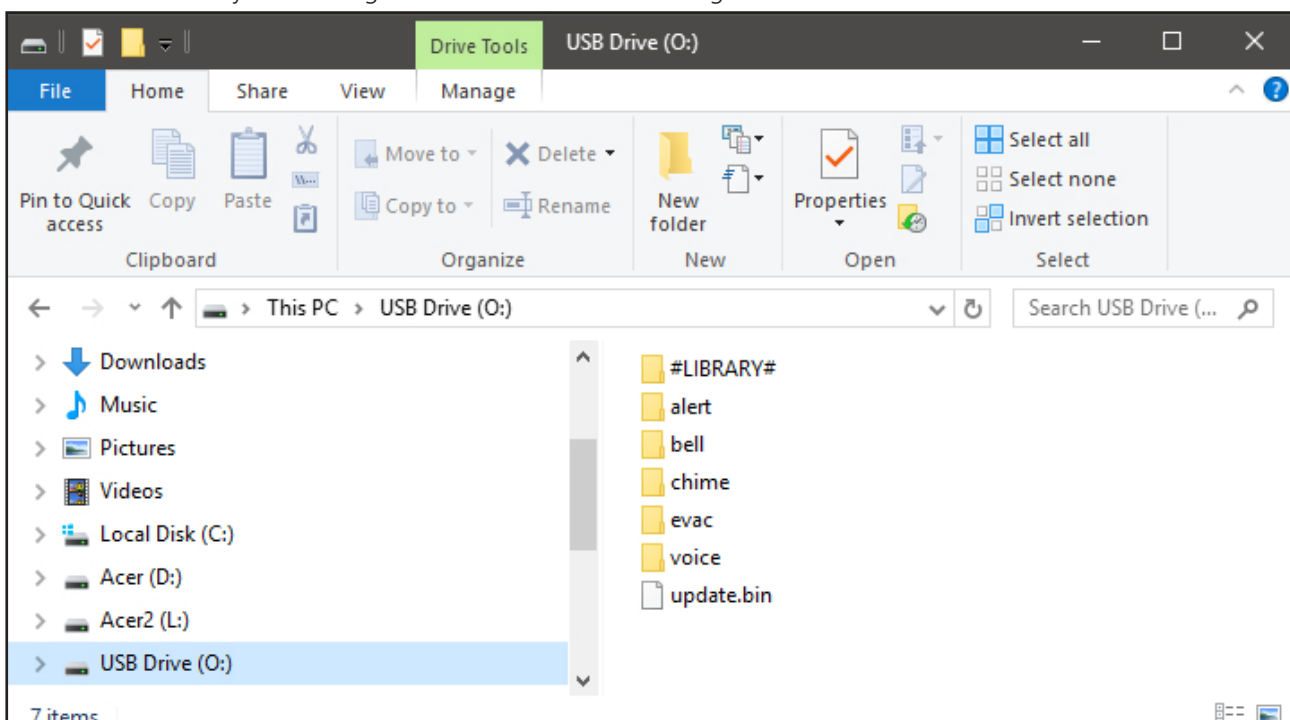

Fig 6

Redback® A 4574 Alert/Evac/Chime Tone Generator

The contents of the Micro SD Card include a Library folder of sample MP3 files and five folders for the MP3 files associated with the various functions of the A 4574.

There should be default MP3 files included in each folder. These will need to be replaced with your own MP3 files.

Open the folder in which you want to install an MP3 (in our case its the Alert folder) and you should see an MP3 file which is named Alert.MP3 as shown in figure 7.

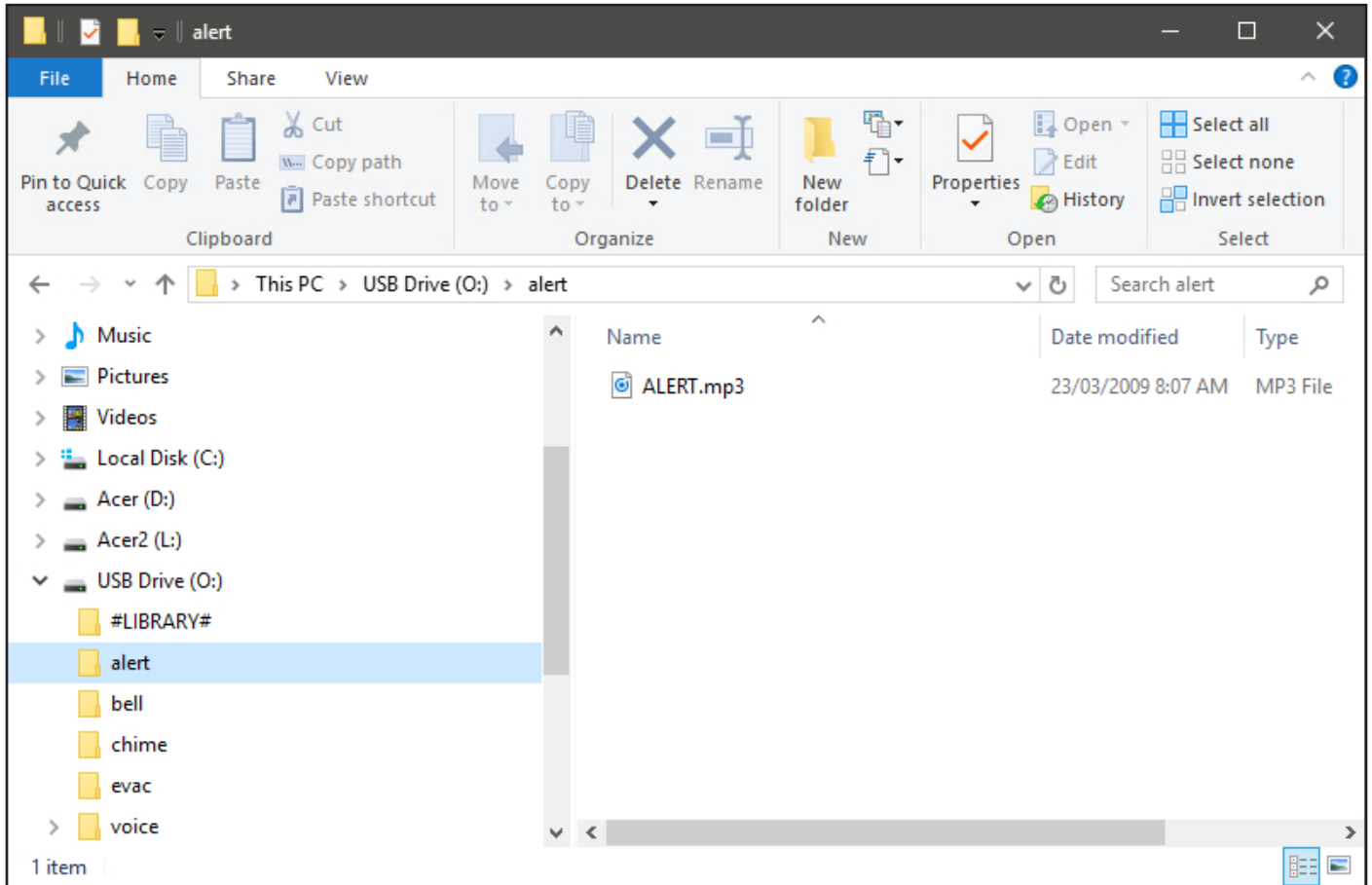

Fig 7.

This MP3 file needs to be deleted and replaced by the MP3 file you want to play when you activate the Alert mode. The MP3 file name is not important. But it is important that there is only one MP3 file in the Alert folder.

Check the properties of the MP3 file.

NOTE the new MP3 file cannot be "Read only".

To check this, right click on the MP3 file and scroll down and select Properties, you will get a window that looks like figure 8.

Make sure the "Read Only" box has no tick in it.

The new MP3 is now installed on the card. Repeat these steps for the other MP3 folders if you need to.

Step 7: The card can be removed from the PC following windows safe card removal procedures. Make sure the A 4574 is OFF and insert the Micro SD card into the slot in the front; it will click when fully inserted. The A 4574 is ready to use.

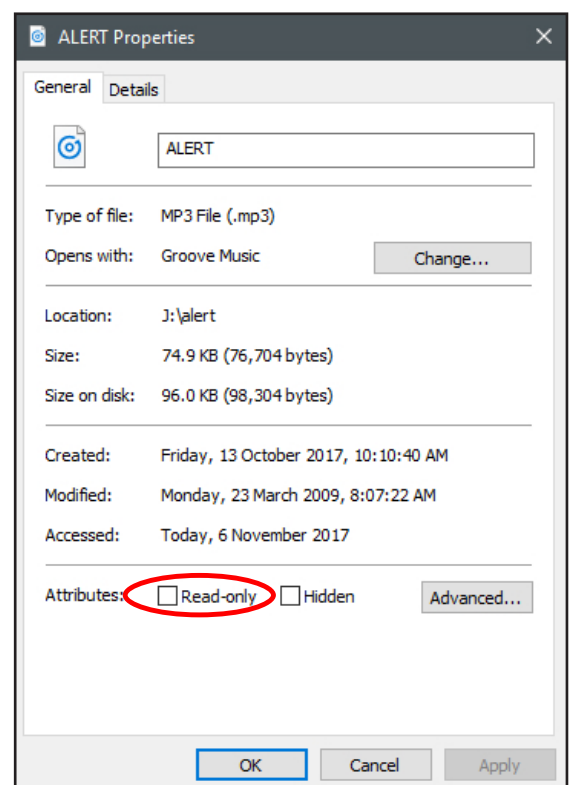

Fig 8

12.0 Optional Remote Wall Plates

There are two optional remote wall plates which can be connected to the A 4574 for remote triggering of the Alert, Evacuation and Bell tones and for remotely cancelling any tones which may be active.

12.1 A 2078B Remote Plate



The A 2078B wall plate provides a remote means of triggering the Alert and Evacuation tones and the cancel function. Connection is made to the A 4574 via a minimum of 7 wires as shown in Fig 9.

If standard Cat5 cable is used for the wiring, the plate can be located up to 30m away from the main unit. This can be increased to 100m away using heavier gauge cable, which reduces the voltage drop across this distance and ensures the switch LEDs illuminate.

The Alert/Evac/Cancel switches on the A 2078B wall plate are connected to the corresponding contacts on the rear of the A 4574. While the Alert and Evac LEDs on the wall plate are connected to the Alert 24V and Evac 24V outputs of the A 4574. The cancel LED is not connected. A minimum of seven wires can be used if the ground connections of the Alert and Evac 24V outputs are linked and if the Alert/Evac and cancel switch grounds are linked together (see Fig 9).

A 4574 REAR PANEL

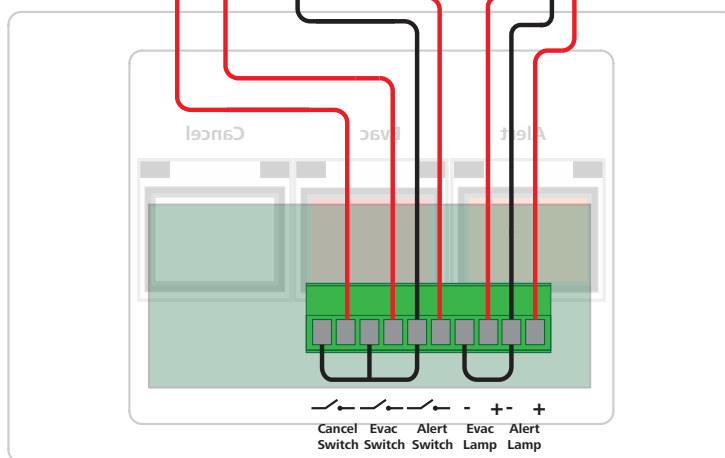
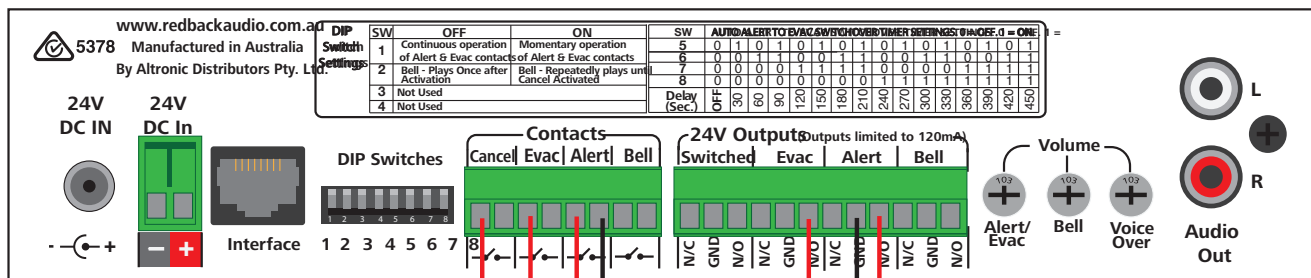

A 2078B REMOTE WALL PLATE

Fig 9

Redback® A 4574 Alert/Evac/Chime Tone Generator

12.2 A 2081 Remote Plate



The A 2081 wall plate provides a remote means of triggering the Alert, Evacuation and Bell tones and the cancel function. Connection is made to the A 4574 via a minimum of 8 wires as shown in Fig 10. If light duty cable is used for the wiring (such as Cat5e/6 cable), the plate can be located up to 30m away from the main unit. This can be increased to 100m away using heavier gauge cable, which reduces the voltage drop across this distance and ensures the switch LED's illuminate.

The Alert/Evac/Chime/Cancel switches on the A 2081 wall plate are connected to the corresponding contacts on the rear of the A 4574. While the Alert, Evac and Bell LEDs on the wall plate are connected to the Alert, Evac and Bell 24V outputs of the A 4574. The cancel LED is not connected. A minimum of eight wires can be used if the ground connections of the Alert, Evac and Bell 24V outputs and the grounds of the Alert/Evac/Chime and cancel switches are linked together (see Fig 10).

A 4574 REAR PANEL

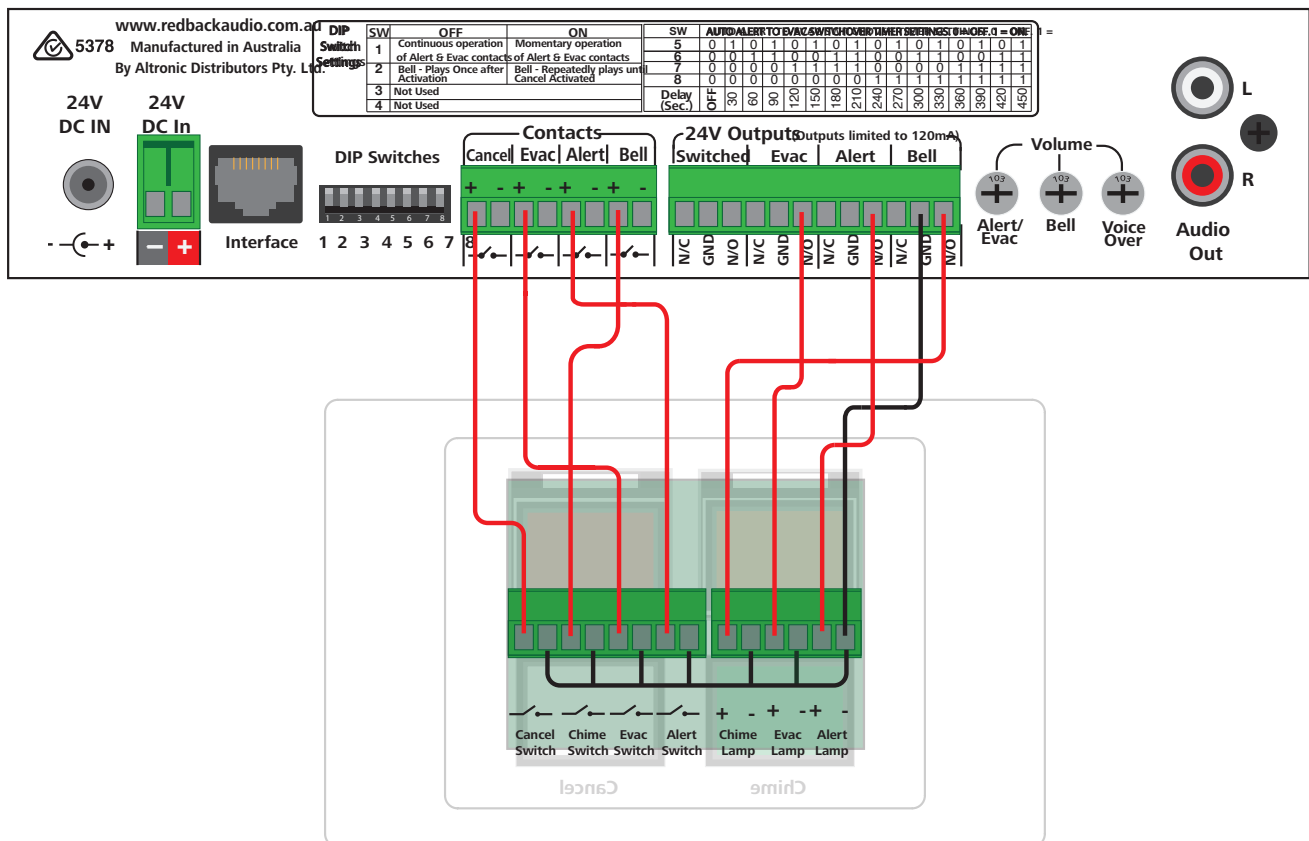

A 2081 REMOTE WALL PLATE

Fig 10

13.0 Troubleshooting

SYMPTOMS	REMEDIES
Fault LED flashes	Make sure the Alert, Evac and Bell folders on the Micro SD card have MP3 files in them.
MP3 Audio files not playing.	Make sure they are in MP3 format. Make sure Micro SD card inserted properly. Check MP3 is installed in appropriate folder.
Alert/evac tone levels are low.	Adjust Evac volume on rear of unit.
Bell volume is low	Adjust Bell volume on rear of unit.
Unit will not play MP3 files or Fault LED flashes.	Make sure all MP3 files are not "Read Only". See page 8.
Power switch is illuminated Red but unit doesn't work	The unit is in standby mode. Press the Power/Standby switch. The unit is ON when the Blue ON LED is illuminated.
Alert or Evac message not playing.	Check MP3 is installed in a voice folder.
DIP switch changes not effective.	Turn the unit OFF before changing DIP switch settings. Settings become effective after power is returned.
I don't know how to record a message.	This unit does not have a recording facility. A message MP3 will have to be recorded on a PC or some other equipment.
24V DC outputs stop working.	These outputs are limited to 120mA output and will trip the internal fuse when overloaded. They will reset once they have cooled down.

14.0 Firmware Update

It is possible to update the firmware for this unit by downloading updated versions from redbackaudio.com.au. To perform an update, follow these steps.

- 1) Download the Zip file from the website.
- 2) Remove the Micro SD card from the A 4574 and insert it into your PC. (Follow the steps on page 6 to open the SD card).
- 3) Extract the contents of the Zip file to the root folder of the SD Card.
- 4) Rename the extracted .BIN file to update.BIN.
- 5) Remove the SD card from the PC following windows safe card removal procedures.
- 6) With the power turned OFF, insert the Micro SD card back into the A 4574.
- 7) Turn the A 4574 ON. The unit will check the Micro SD card and if an update is required the A 4574 will perform the update automatically.

Redback® A 4574 Alert/Evac/Chime Tone Generator

15.0 Specifications

OUTPUT LEVEL:.....0dBm	CONTROLS:
DISTORTION:.....0.01%	Bell, Alert/EvacTones:.....Rear Volume
FREQ. RESPONSE:.....140Hz - 20kHz	Voice over.:.....Rear Volume
SIGNAL TO NOISE RATIO:	Power:.....On/Off Switch
Alert/Evac/Chime:.....-70dB typically	Alert Switch:.....Illuminated Push Switch
OUTPUT CONNECTORS:	Evac Switch:.....Illuminated Push Switch
Audio Output:.....RCA Stereo Socket	Bell Switch:.....Illuminated Push Switch
Switched 24V DC Out:.....Screw Terminals	Cancel Switch:.....Push Switch
Alert 24V DC Out :.....Screw Terminals	INDICATORS:.....Power on
Evac 24V DC Out:.....Screw TerminalsFault
Bell 24V DC Out:.....Screw Terminals	POWER SUPPLY: 24V DC @ 1 Amp
<i>PLEASE NOTE: Output loads limited to 120mA.</i>	DIMENSIONS:≈..... 210W x 122D x 44H
INPUT CONNECTORS:	WEIGHT: ≈..... 0.4 kg
24V DC Power:.....Screw Terminals	COLOUR:Black
24V DC Power:.....2.1mm DC Socket	
Remote Alert,Evac,Bell,Cancel:.....Screw Terminals	
AUDIO STORAGE:	
Micro SD Card:Max 16GB	

* Specifications subject to change without notice

All Australian made Redback products are covered by a 10 year warranty.

Should a product become faulty please contact us to obtain a return authorisation number. Please ensure you have all the relevant documentation on hand. We do not accept unauthorised returns. Proof of purchase is required so please retain your invoice.