



Operating Manual A 4935 3 Mic + Line Input Preamp Wallplate

OVERVIEW:

The Redback® A 4935 accepts either a microphone or line input and converts the signal to a balanced high level output. The high level output signal is carried via Cat5e cable, (suitable for distribution up to 300m without interference) back to Redback® compatible devices such as the Redback® A 4930 Hub, Redback® A 4493 Source selector wall plate or Redback® A 4453 Input/Output Selector wall plate.

Microphone inputs are balanced XLR inputs, while the Line input is via 2 x RCA sockets, or 3.5mm audio jack for portable devices.

Each input has it's own dedicated volume while a master volume sets the overall output volume.

VOX muting is available which mutes the AUX and Music inputs when any microphone input is active. The VOX sensitivity is adjustable via the front of the wallplate.

SPECIFICATIONS:

Frequency Response

Mic input:.....140Hz - 20kHz
 Aux input:.....140Hz - 20kHz
 Music input:.....140Hz - 20kHz

Input Sensitivity

Mic input: 3mV balanced
 Aux input: 300mV - 1V balanced
 Music input: 300mV - 1V balanced

Connectors

Mic Input: 3 pin XLR
 Aux Input: 2 x RCA
 Music Input: 3.5mm Stereo Socket

Output: RJ45 8P8C

Data transmission: Cat5e/6 cabling (max 300 metres)

Weight: ≈0.19kg

Dimensions: ≈ 145mm(L) x 115mm(W) x 50mm(H)

Power: Powered over Cat5e/6 cable

Redback® A 4935 Balanced Mic/Line Preamp Wallplate

CONNECTING THE A 4935 WALL PLATE TO THE A 4930 MIC/LINE HUB

Figure 1 shows the connection diagram when connecting the A 4931 or A 4935 wall plates to the Redback® A 4930 Mic/Line Hub. The A 4931 and A 4935 wall plates can be connected to any of the four wall plate RJ45 connectors as shown. The A 4935 has a set of DIP switches on the rear which determine how the audio is output from the wallplate.

When the A 4935 is used with the A 4930 there are only two possible audio output options.

1) The audio from the A 4935 wallplate microphone inputs and the line and/or music inputs are mixed together and output to the A 4930 Hub.

DIP Switches set as follows: 1-OFF ,2-OFF, 3-OFF, 4 - OFF (Not Used).

2) The A 4935 wallplate microphone inputs have VOX priority over the AUX and Music inputs. I.e. the audio from the AUX/Music inputs will be over ridden by the Mic inputs when a microphone is used.

DIP Switches set as follows: 1-OFF ,2-ON, 3-OFF, 4 - OFF (Not Used).

The VOX sensitivity of the microphones is adjusted by the VOX sensitivity pot on the front of the A 4935.

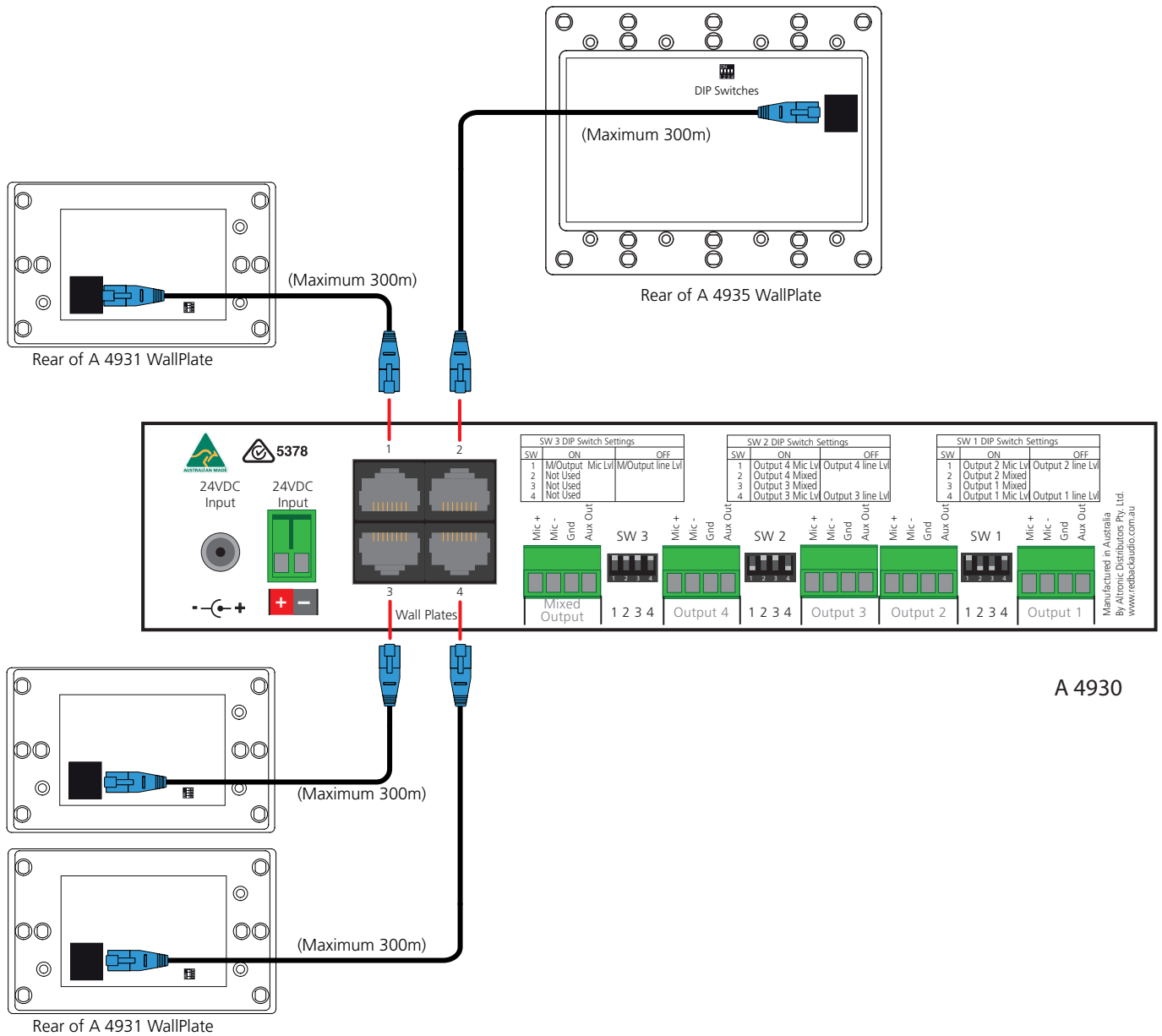

Fig 1.

Redback® A 4935 Balanced Mic/Line Preamp Wallplate

CONNECTING THE A 4935 WALLPLATE TO THE A 4493 SOURCE SELECTOR WALL PLATE

Figure 2 shows the connection diagram when connecting the A 4935 wall plates to the Redback® A 4493 Zone Selection plates. The A 4493 wall plates are typically used with the Redback® A 4480B 8 x 8 Audio Switcher.

The A 4935 has a set of DIP switches on the rear which determine how the VOX (voice operated switch) priority functions.

Dip switch 3 when set to ON, activates the VOX function. If this switch is in the OFF position the audio from the A 4935 will only override the A 4493 Input Source Wall Plate if the "Local Input" button has been selected on the A 4493 (see relevant instruction manual for details). In this mode the Mic and AUX/Music input from the A 4935 will be mixed - there is no priority.

If DIP switch 3 is set to ON then the following VOX priorities result from DIP switches 1 and 2 without the need for the "Local Input" button to be selected on the A 4493 Input Source Wall Plate.

DIP Switch 1 set to ON: The Microphones and the AUX/Music input will mix together and the audio from the A 4935 will then override the A 4493 zone input audio source.

DIP Switch 2 set to ON: The Microphones only, will activate the VOX circuit and mute the AUX/Music input if used. The audio from the A 4935 will then override the A 4493 zone input audio source.

DIP Switch 4 set to OFF (Not Used)

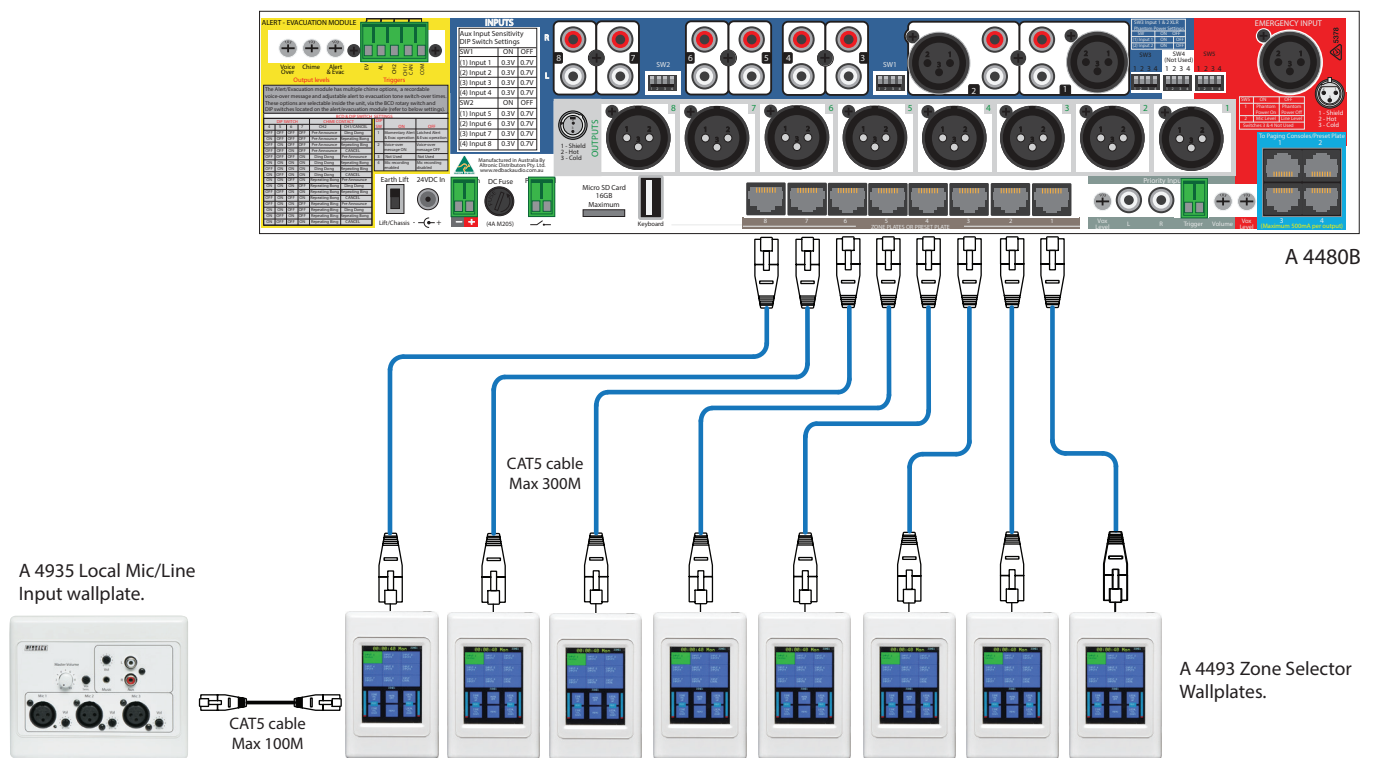

Fig 2.



REDBACK

You may be surprised to learn that Redback is still manufacturing hundreds of product lines right here in Australia. We have resisted the move offshore by offering our customers better quality products with innovations to save them time and money.

Our Balcatta production facility manufactures/assembles:

Redback public address products
One-shot speaker & grill combinations
Zip-Rack 19 inch rack frame products

We strive to support local suppliers wherever possible in our supply chain, helping to support Australia's manufacturing industry.

Redback Audio Products

100% developed, designed & assembled in Australia.

Since 1976 we have been manufacturing Redback amplifiers in Perth, Western Australia. With over 40 years experience in the commercial audio industry, we offer consultants, installers and end users reliable products of high build quality with local product support. We believe there is significant added value for customers when purchasing an Australian made Redback amplifier or PA product.

Local support & feedback.

Our best product features come as a direct result of feedback from our customers, and when you call us, you speak to a real person - no recorded messages, call centres or automated push button options.

It's not only the assembly team at Redback who are employed as a direct result of your purchase, but hundreds more at local companies used in the supply chain.

Industry leading 10 year warranty.

There's a reason we have the industry leading DECADE warranty. It's because of a long tried and tested history of bullet-proof reliability. We've heard PA contractors tell us they still see the original Redford amplifier still in service in schools.

We offer this comprehensive parts & labour warranty on almost every Australian Made Redback public address product. This offers both installers and end users peace of mind that they will receive prompt local servicing in the rare event of any problems.