



Operating Manual

OVERVIEW

This compact module has been designed to alter the volume of any low level signal source feeding any amplifier or mixer remotely, via RS 232 or RS 485, or via the Redback® A 2280B remote volume wallplate.

The Redback® A 6512 will interface directly to the Redback® A 6500 wallplate or any other third party control system which utilises RS232 or RS485 serial codes.

Fig 1 shows the layout of the front of the A 6512.

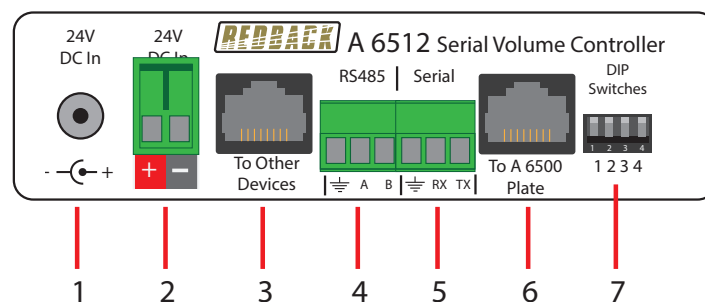

Fig 1.

- 1 24V DC input**
Connects to a 24V DC Plugpack with a 2.1mm Jack (Please observe the polarity, centre positive).
- 2 24V DC Input**
Connects to a 24V DC source via a euro block (Please observe the polarity).
- 3 RJ45 interface**
This RJ45 port is for connection to other Redback® compatible devices.
- 4 RS485 Serial Input**
This input takes an RS485 input signal. This can be connected to the RS485 serial output of the Redback® A 6505 or to a third party system. Follow standard RS485 wiring when connecting these terminals.
- 4 RS232 Serial Input**
This input takes an RS232 input signal. This can be connected to the RS232 serial output of the Redback® A 6505 or to a third party system. Follow standard RS232 wiring when connecting these terminals.
- 6 RJ45 interface**
This RJ45 port is for connection to the Redback® A 6500 wall plate.
- 7 DIP Switches**
1 ON: Accept serial codes through RS485 input.
2 ON: Accept serial codes through RS232 input.
3 ON: Accept serial codes from Redback® A 6500 wall plate.
4: Not Used

Redback® A 6512 Single Input Serial Volume Controller

CONNECTIONS

Figure 2 illustrates a typical connection diagram when using the Redback® A 6500 wallplate or a third party controller to control the Redback® A 6512 Serial Volume Controller.

The Redback® A 6500 connects via a Cat5e/6 lead into the "To A 6500" RJ45 connection port of the Redback® A 6512. 24V DC power is supplied to the Redback® A 6512 via a 24V DC plugpack or other 24V DC source (minimum 24V DC 1A). Serial control of the volume circuit is provided by the A 6500 wallplate which is programmed with the serial codes using the PC software supplied with the Redback® A 6500. (Refer to the Serial Codes section for details).

The third party controller sends RS232 or RS485 codes directly to the corresponding RS232 or RS485 input connector of the Redback® A 6512. The code must be sent in the correct format as outlined in the Serial Codes section.

In this example the audio into the Redback® A6512 volume controller is provided by a DVD player with a standard RCA line level output. The attenuated signal is then output out of the Redback® A 6512 volume controller into the line level input of an amplifier.

The output volume of the Redback® A 6512 is set by the serial codes sent to the unit as outlined in the Serial Codes section.

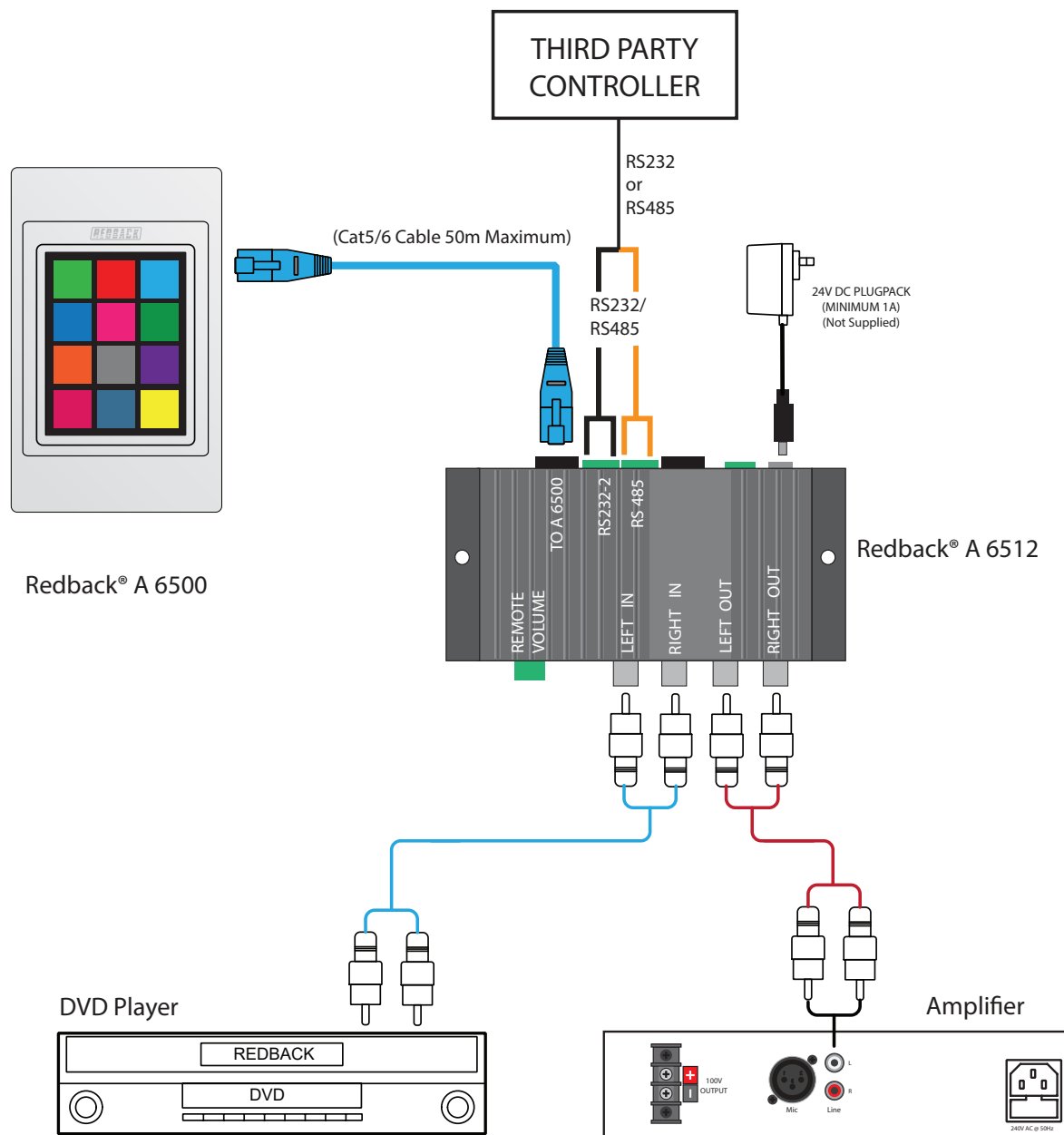

Fig 2.

Figure 3 illustrates an example where not only does the Redback® A 6512 need to be controlled but also other devices require control from the Redback® A 6500 wallplate. In this example the Redback® A 6500 is connected to the Redback® A 6505 via the Cat5e/6 cable which then passes through serial codes to the Redback® A 6512 via the RS485-1 terminals or RS232-1 terminals.

The Redback® A 6505 can then control relays, the IR repeater and send serial codes out the second serial port to other equipment.

Redback® A 6512 Single Input Serial Volume Controller

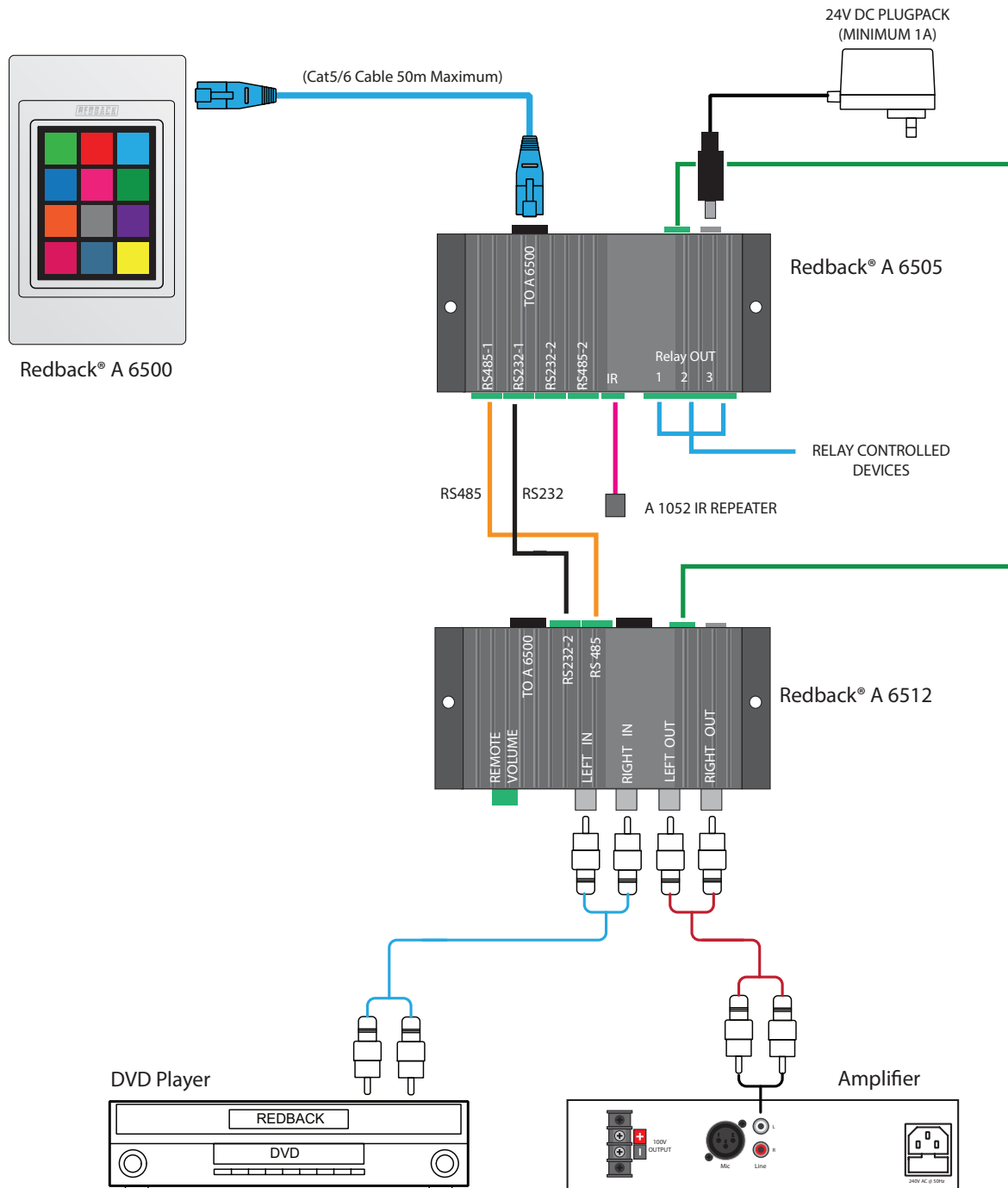

Fig 3.

SERIAL CODES

The Redback® A 6512 Serial Volume Controller output level is adjusted by sending serial codes sent in the following format. The serial data sent has to be transmitted at 9600 baud, with the stop bit set to 1, data bits to 8, parity to none and the format must be ASCII.

Note: If the Redback® A 6500 wallplate is being used to send the serial codes, set the delay to 100ms.

Function:

The output level can be set to a given level between 0 (Off) and 79 (maximum).

To set these levels simply send the code VOLUMES? where ? is the number between 0 and 79.

The output level can also be increased or decreased by sending the following codes.

Increase Level = VOLUMEUX (where U stands for UP).

The X is the value to increase the volume. e.g VOLUMEU5 would increase the volume 5 steps.

Decrease Level = VOLUMEDX (where D stands for DOWN).

The X is the value to decrease the volume. e.g VOLUMED10 would decrease the volume 10 steps.

If power to the A6512 is removed the unit will remember its last Level setting when power is restored.

Redback® A 6512 Single Input Serial Volume Controller

The output volume of the A 6512 can also be adjusted without the need for serial codes. Simply wiring a 1K Ω potentiometer or a Redback® A 2280B wallplate to the remote volume terminals will perform the same function. The wiring is illustrated in figure 4.

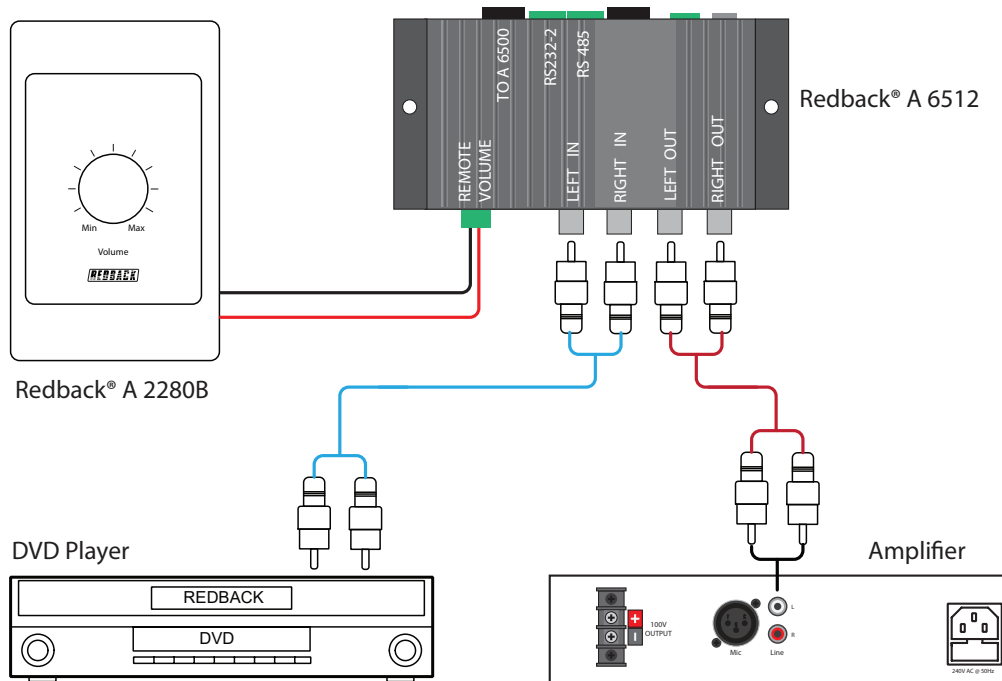
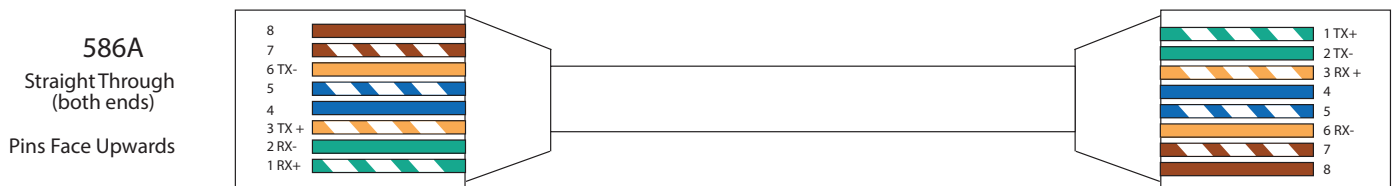

Fig 4.

RS485 - RJ45 cabling configuration for system components (586A 'Straight through')

System components are connected using "pin to pin" configuration RJ45 data cabling as shown below. When installing ensure all connections are verified with a LAN cable tester before switching any system component on.

Failure to follow the correct wiring configuration may result in damage to system components.



All Australian made Redback products are covered by a 10 year warranty.

Should a product become faulty please contact us to obtain a return authorisation number. Please ensure you have all the relevant documentation on hand. We do not accept unauthorised returns. Proof of purchase is required so please retain your invoice.