

**Product Guide****C 1065** Fast-Fix® Ceiling Mount 10" 240W Subwoofer 4 Ohm/100V

## Ceiling Mount 10" 240W Subwoofer 4 Ohm/100V

- ✓ Provides added low end frequency for retail PA music systems.
- ✓ Commercial grade 10" driver.
- ✓ Long life premium rubber surround.
- ✓ Includes backcover for superior bass performance.
- ✓ Power adjustment inside front grille.
- ✓ Flip-lock mounting system reduces installation time.
- ✓ 100V line or 4 Ohm connection.
- ✓ 5 year warranty.



### Application

This High power commercial grade 10" subwoofer is ideal for providing additional low end response to foreground music and hi-fi applications. Built in 100V line transformer makes it suitable for integration with commercial systems in fashion boutiques, shopping centres, gymnasiums etc. The enclosed metal dome offers physical protection and extends bass response. If mounting into a tiled ceiling, the C 1066 tile bridge should be utilised for a secure installation. Ideally paired with A 4861 subwoofer amp.

### Power Selection:

Behind the front grille a selector switch provides 100V power tap and 4 ohm selections.



### Loop In / Loop Out Wiring:

Rear terminal connection provides strain relief for cabling, plus loop in, loop out wiring for use in 100V line systems. Terminal is protected from dust and debris by a screw secured cover.

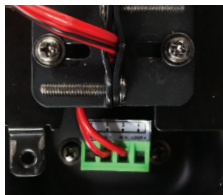

### Testing

Redback® drivers are subject to strenuous factory testing reducing the risk of unit failure or performance reduction over time. Each driver has a power rating well above the max tapping of the transformer, ensuring reliable operation and excellent longevity.

### About the Fast-Fix Flip Lock System.

Redback® "Fast-Fix" speaker utilise a time saving flip lock mounting method. It results in a finish with no visible screw heads or caps. The flip lock tabs slide outwards as the speaker is screwed into the hole, securing the speaker to the ceiling material from the top side. Suitable for use with any 8-33mm ceiling tile, including gyprock, mineral fibre or fixed gyprock ceilings.

### Installation Guidelines

Due to the weight of the speaker, we recommend the unit be tethered to the ceiling with a safety chain.

Speaker is supplied with internal mounting ring for use with solid ceilings. For installation with tiled ceilings we recommend cross support with the C 1066 installation panel. This provides added support behind the ceiling tile to prevent sagging.

### About Redback® Speaker Drivers

Each custom designed speaker and transformer combination has been specifically engineered to ensure a wide frequency range and dispersion angle, plus a high sound pressure level (SPL) ensuring excellent music and speech intelligibility; which is highly desirable for paging applications.

Redback® drivers exhibit optimum frequency response and efficiency for BGM & paging applications. The transformers are wound on professional grade grain oriented steel cores for high efficiency and extended frequency response.

Each transformer is fitted with multiple power tapings which are selected via a tab on the top of the transformer.

## Product Guide

**C 1065** Ceiling Mount 10" 240W Subwoofer 4 Ohm/100V



### Dimensions & Transformer Detail

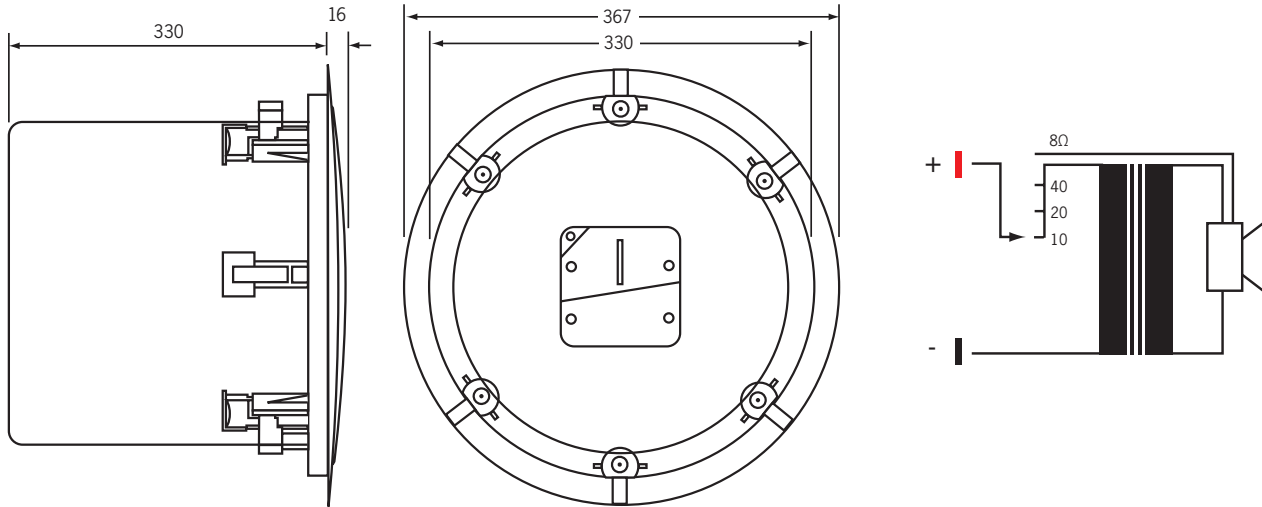

### Specifications

#### Electrical

Power taps:	60, 120, 240W
Rated power:	240W @ 4Ω
Max SPL:	112dB
Frequency response:	30Hz-15kHz
Connection:	4 way terminal block

#### Mechanical

Driver construction:	Polypropylene
Ceiling cutout:	330mmØ
Grille diameter:	367mmØ
Grille material:	Powdercoated steel
Mounting depth:	330mm (including ceiling tile thickness)
Overall weight:	7.5kg

#### Environmental

Operating temperature:	-25°C to +55°C
Relative humidity:	< 95%

#### Additional Installation Accessories

**C 1066** Ceiling tile support

**H 3900** Galvanised jack chain for installation

### Architectural Specifications

#### C 1065

The speaker shall be a subwoofer type measuring 10" in diameter and rated to 240W RMS at 4 ohms. The speaker shall be fitted with 100V line transformer with 60, 120 and 240W power taps and enclosed dome on rear of speaker. The speaker model shall be Redback brand, model number C 1065.