

**Product Guide****C 1520** 20W 100V Line IP65 Rated Sound Projector White

## 20W Weatherproof Sound Projector

- ✓ Tough UV stabilised high impact ABS construction
- ✓ Durable powdercoated aluminium mounting bracket
- ✓ Stainless steel grille & fixings
- ✓ Exceptional music and speech reproduction
- ✓ Selectable power taps
- ✓ Uses a high efficiency driver and line transformer
- ✓ Suitable for indoor or outdoor use
- ✓ Includes 7-core cable for easy power tap selection
- ✓ Fitted with supervisory capacitor for line monitoring.
- ✓ 5 year warranty.



### Application

This Redback® sound projector is made from strong UV stabilised ABS plastic with a perforated metal grille.

Its wide dynamic range facilitates use with both paging and background music applications eg: sports stadiums, train station platforms, shopping centres, aquatic arenas, etc.

### About Redback® Speaker Drivers

Each custom designed speaker and transformer combination has been specifically engineered to ensure a wide frequency range and dispersion angle, plus a high sound pressure level (SPL) ensuring excellent music and speech intelligibility; which is highly desirable.

Redback® drivers exhibit optimum frequency response and efficiency for BGM, paging and EWIS applications. The transformers are wound on professional grade grain oriented steel cores for high efficiency and extended frequency response.

Each transformer is fitted with multiple power tapings which are selected via a tab on the top of the transformer.

### Installation Guidelines

These models are a 100V line horn speaker designed for direct connection to a commercial amplifier with 100V output. It is fitted with a 300mm seven core cable. Each coloured cable core is connected to a power tap on the transformer. Selection is made by connecting between common and the required power tap cores.

The speaker is supplied with a stainless steel bracket, grille and fixings ensuring rust-free performance even in harsh environments.

The neutral grey RAL colour of C 1520 provides an architecturally unobtrusive finish to virtually any installation. Also available in black version for dark ceilings/walls (C 1549).

### Testing

Redback® drivers are subject to strenuous factory testing reducing the risk of unit failure or performance reduction over time. Each driver has a power rating well above the max tapping of the transformer, ensuring reliable operation and excellent longevity.

## Product Guide

**C 1520** 20W 100V Line IP65 Rated Sound Projector White



### Dimensions & Transformer Detail

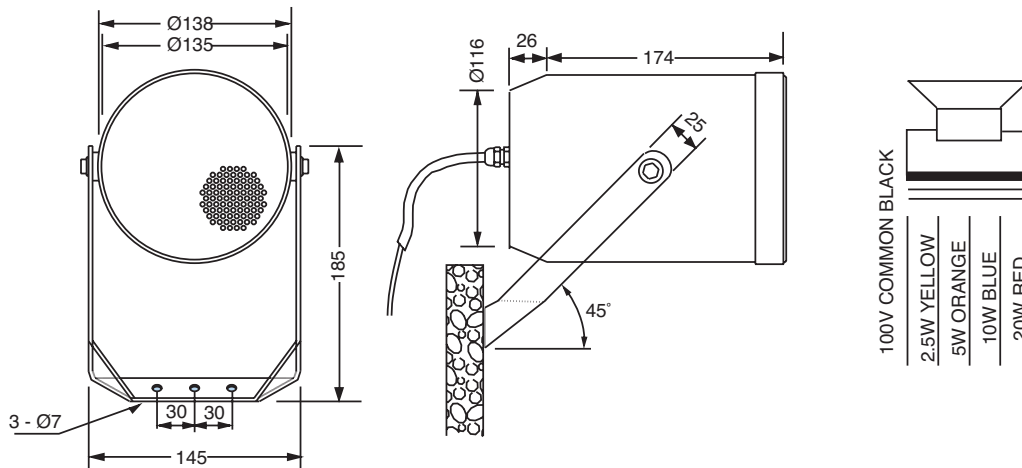

### Specifications

#### Electrical

Rated Power:	20W
Power taps:	2.5, 5, 10 & 20W
SPL 1W @ 1m:	91dB @ 1kHz (+/- 2dB)
SPL full power @ 1m:	104dB @ 1kHz (+/- 2dB)
Frequency response:	110Hz-18kHz
Transformer impedance:	500Ω / 1kΩ / 2kΩ / 4kΩ
Dispersion:	180°/120°
Directivity Q factor, 1kHz	2.6φ/ 5.6φ
Connection:	7 core cable
IP Rating:	66
Tappings 70.7V Line:	10/5/2.5/1.25W
Max/Min Ambient Temp:	70°/-25°
Driver Impedance:	8Ω
Acoustic Power (dB-PWL @1W) 1k/2kHz):	89/90 dB

#### Mechanical

Driver construction:	Coaxial 2-way driver with coated cone
Housing construction:	ABS plastic
Mounting hardware:	Stainless steel with aluminium bracket
Dimensions:	138Ø x 204Dmm
Colour/Finish:	White
Overall weight:	1.6kg

### Polar Plot

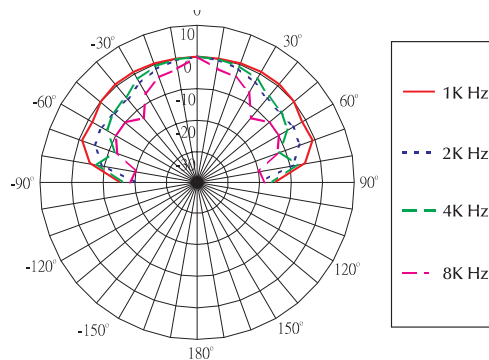

### Response Graphs

