



16 Channel UHF Wireless Microphone Systems

C 8867C: Receiver & Handheld Transmitter Microphone

C 8868C: Receiver & Beltpack Transmitter



Operating Instructions

OVERVIEW:

This switching diversity system is the perfect entry level wireless microphone system for clubs, restaurants, function centres, wedding ceremonies etc. produce a clear, crisp vocal reproduction, while allowing freedom of movement. The unit is supplied as a complete system with either handheld or beltback/lavalier microphone transmitters included in the package. 16 channels within a single tuner allows interference free operation, making it possible to use up to six receivers in one location. Output signal is via 3 pin XLR balanced or 6.35mm unbalanced jack, suitable for connection to most amplifiers. Front panel LED's indicate active antenna and audio signal presence.

FEATURES:

- 16 Channels in the 520-550MHz UHF Band
- Switching Diversity Receiver with front facing antennas
- Rotary channel controller on receiver
- High receiving sensitivity
- RF and AF signal presence LEDs
- Tone squelch circuitry for noise reduction
- Range up to 70m in ideal conditions
- 6.35mm unbalanced line/mic output
- 3 pin balanced XLR mic output
- Microphone transmitters require 2 x AA batteries (not included).

In The Box:

- Receiver with antennas fixed
- Microphone transmitter (handheld or lavalier beltpack)
- Antennas
- Manual

SYSTEM SPECIFICATIONS:

Carrier Frequency Range:	520-550MHz UHF band
Frequency Stability:	±0.005%
Oscillator:	PLL Synthesised
Receiving Sensitivity:	10µV over 80dB S/N ratio
Image and Spurious Rejection:	80dB minimum
Selectivity:	>50dB
Modulation Mode:	FM
IF Frequency:	1st: 243.95MHz; 2nd: 10.7MHz
Tone Signal:	32.768kHz
S/N ratio:	>94dB, at 48kHz deviation and 60dBµV antenna input
Audio Frequency Response:	50Hz to 15kHz (±3dB)
Total Harmonic Distortion:	Less than 1.0% (at 1kHz)
Power Supply:	12V d.c.
Audio Output:	Balanced and unbalanced outputs for Single channel / Switching diversity (Mic.=20dB / Line = 0dB)
Current consumption:	130mA (max.)
Dimensions (mm) WxHxD:	170 x 32 x 106

NOTE: TWO OR MORE WIRELESS MICROPHONES (HANDHELD AND/OR LAVALIER) WHICH TRANSMIT AT THE SAME FREQUENCY CANNOT BE USED IN THE SAME LOCATION.

DESIGN AND SPECIFICATIONS SUBJECT TO BE CHANGED WITHOUT NOTICE.

PRECAUTIONS:

- AVOID EXTREMELY DIRTY OR DUSTY ENVIRONMENTS.
- AVOID AREAS WHERE THERE IS EXTREMELY HIGH HUMIDITY.

Figure 1: Front and Rear Panels

1. Antenna: Fixed-length UHF antenna permanently mounted on the front panel.
2. PWR: The indicator LED illuminates when the receiver is ready to operate.
3. AF: The indicator LED illuminates to indicate that audio signal has been received.
4. DIVERSITY A - B: This indicator LED illuminates to show that antenna has received the RF Signal.
5. BALANCED: 3-pin XLR output connector provides balanced low-impedance output.
6. UNBALANCED: 6.35mm mono jack audio output for connecting to e.g. a guitar amplifier.
7. MIC/LINE: Switch to select output of XLR balanced connector or 6.35mm unbalanced phone jack. This can be set for microphone (-20dB) or line-level (0dB).
8. CHANNEL: Rotary selector switch with 16 different selectable frequencies.
9. SQ: Adjusts the output level to prevent external noise. Setting the Squelch too high will reduce system range.
10. DC INPUT: Input connector for the supplied AC/DC adaptor.

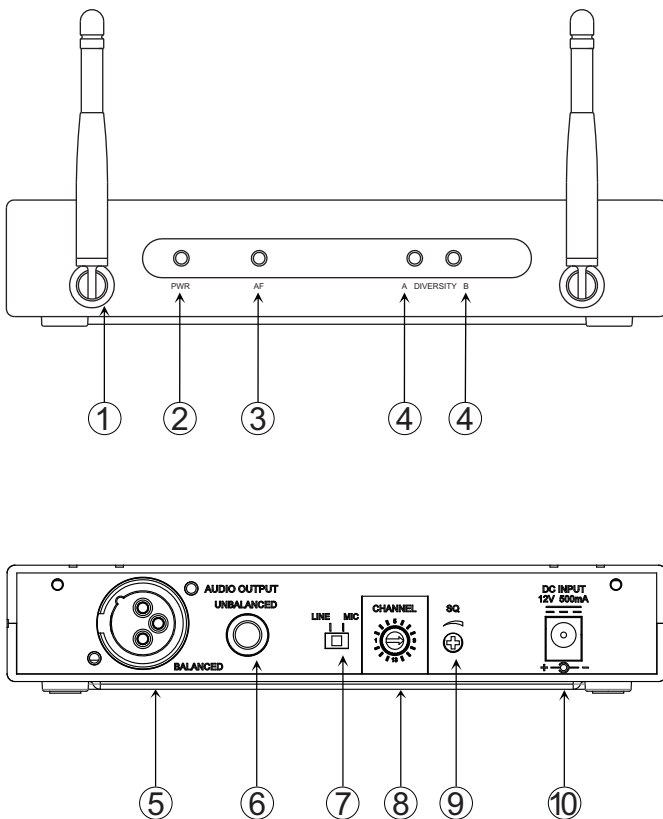

INSTALLATION:

- Do not use two transmitters set to the same frequency.
- Always use good quality batteries to avoid any damage that may result from a defective leaking battery.
- Install the receiver in locations away from metal objects and avoid obstructions between the transmitter and receiver.
- To avoid interference, do not place the receiver adjacent to TV, radio, and other wireless appliances where possible.
- Set the transmitter and receiver to the same frequencies. To do this, change the channel frequency selection switch so that the transmitter and receiver are set to the same frequency. These will provide optimum performance with multiple systems.
- Never use the balanced and unbalanced audio outputs at the same time. This may cause signal loss or increased noise.
- Set the squelch to minimum before connecting the receiver power supply.
- Connect the a.c. adaptor and the power light should illuminate.
- Switch on the transmitters (see pages 3 and 4 for transmitter information). Ensure the transmitter is at least one metre from the receiver.
- Check for sound quality by moving the transmitter around the area where you wish to use the system, to look for dead spots. If you find any dead spots, change the receiver position.

Note: If user needs to set up a multi-receiver system, please keep your previous receiver-microphone pair powered on. Then repeat the setup procedure for the other receiver – transmitter pairs.

**Figure 2: C 8867C
Handheld Transmitter**

1. Grille: Protects the microphone capsule and helps reduce breath sounds and wind noise.
2. Low Battery LED: Indicates battery life status. Solid light – battery ok. Flashing light – battery power low. No LED light indicates dead battery.
3. Power: Press for a few seconds to turn transmitter on or off.
4. Battery Compartment: Ensure batteries are inserted according to the polarity shown.
5. Channel Selector: 16 different selectable transmitter frequencies.
6. Battery Cover: Unscrew to expose battery compartment and channel selector rotary switch.
7. Antenna: Built-in high gain helical antenna.

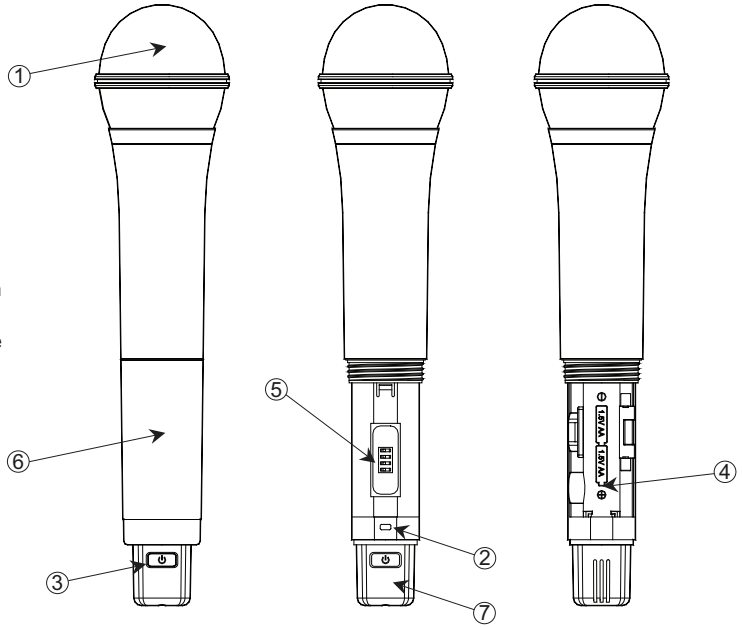

TRANSMITTER SPECIFICATIONS:

Carrier Frequency Range:	520-550MHz UHF band
RF Power Output:	10mW (max.)
Oscillation Mode:	PLL synthesized, 16 Channel selectable
Frequency Stability:	±0.005%
Maximum Deviation:	±48kHz with limiting compressor
Spurious Emission:	>60dB below carrier frequency
Total Harmonic Distortion:	<1% (at 1kHz)
Microphone Capsule:	
Handheld:	uni-directional electret condenser unit
Lavalier:	uni-directional electret condenser unit
Battery:	3V d.c. (2 x 1.5V AA size batteries) or 2.4V d.c. (2 x 1.2V AA size rechargeable batteries)
Current consumption:	120mA +/- 5mA
Dimensions (mm) WxHxD:	Handheld = 266 x 550 Beltpack = 65 x 100 x 27

HANDHELD TRANSMITTER OPERATION (C 8867C model)

1. Insert 2 x 1.5V AA size dry or rechargeable batteries. Note that fully charged rechargeable batteries will not provide power to the unit as long as will good quality alkaline dry cell batteries.
2. Set the channel frequency inside the battery compartment, to match the receiver.
3. Press button for two seconds to turn on the microphone. The LED will stay on to indicate the batteries have sufficient power. If the LED fails to light, the battery is either dead or not positioned correctly. If the LED stays flashing, it indicates that the battery will soon be out of power and should be changed.
4. Set the levels on your audio mixer or amplifier as appropriate.

TROUBLESHOOTING

Problem	Solution
No Sound	<ul style="list-style-type: none"> • Check the power supply of the microphones and receiver. • Check the transmitter and receiver are tuned to the same frequency. • Check whether the audio amplifier is switched on and the receiver output is connected to it. • Check whether the transmitter is too far away from the receiver or if the Squelch control is set too high. • Check whether the receiver is located too close to a metal object or there are obstructions between the transmitter and receiver.
Sound Interference	<ul style="list-style-type: none"> • Check the antenna location. • When using two or more microphone transmitters simultaneously, make sure that they are set to different frequencies. • Check whether interference is coming from other mics or TVs or radios nearby.
Distortion	<ul style="list-style-type: none"> • Check whether the receiver volume is set too high or too low. • Check whether interference is coming from other mics or TVs or radios nearby.

Fig 4. Wireless Receiver Connection Via Mic In

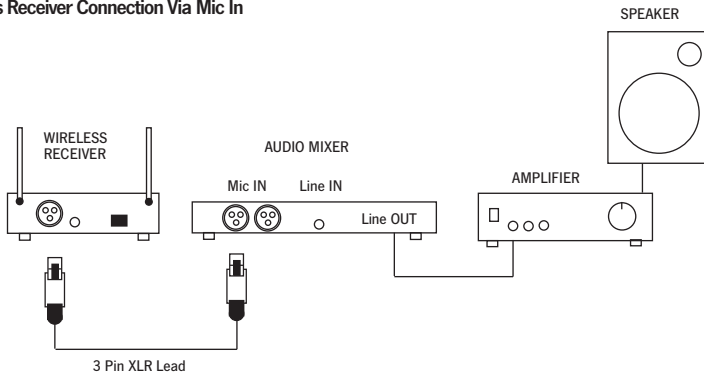
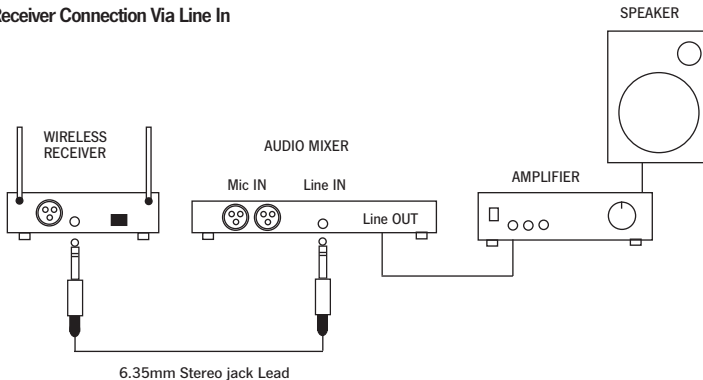

Fig 5. Wireless Receiver Connection Via Line In



For repair or service please contact your place of purchase. Note: Under no circumstances should you attempt to repair the player yourself or via a non-authorized REDBACK service centre as this will invalidate the warranty!
During the warranty period, we undertake to repair or replace your product at no charge if found to be defective due to a manufacturing fault. The warranty excludes damage by misuse, neglect, shipping accident, incorrect installation or no fault found.

NOT FIELD SERVICEABLE.
