

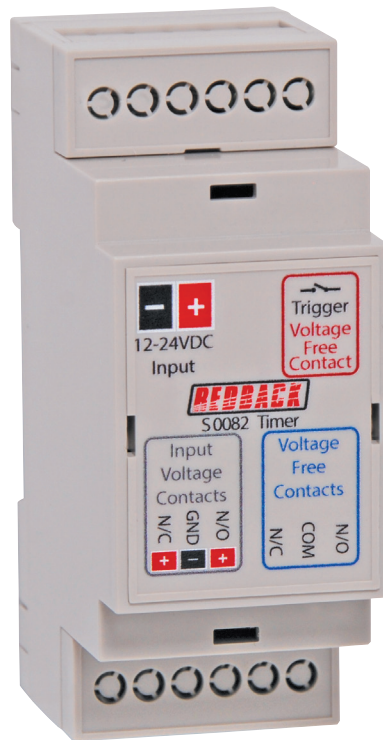

Operating Manual

S0082 DIN rail timer with delay



1.0 OVERVIEW

This compact 12-24VDC timer has a multitude of operating modes. The timing is set via an internal trimpot. DIP switches select the timing range (0-60s, 0-60m or 0-24hrs). All timing events are activated with a closing set of voltage free contacts, or by simply applying power. There are numerous options for how/when the timer starts:

1. Contact closure, timer runs until timeout duration.
2. Contact closes, relay operates instantly, timer starts at release of contact opening. Times for set duration.
3. Contact closes, timer toggles ON or OFF for timer duration until contact opens.
4. Contact closure changes state of relay ie: relay toggles ON or OFF with every contact closure. No timing involved.

Housed in a standard DIN rail mount enclosure it is suited for use in alarm systems, access control, lighting and airconditioning systems. The relay output consists of one set of voltage free contacts and a set of active contacts, the same as the input voltage.

2.0 FEATURES

- Easy to set up
- Multiple operating modes
- Up to 24 hour timing duration
- DIN mount enclosure
- 12-24VDC operation
- 5A relay contacts

Size: 90W x 36D x 57Hmm.

3.0 CONNECTIONS

Figure 1 shows the connection details.

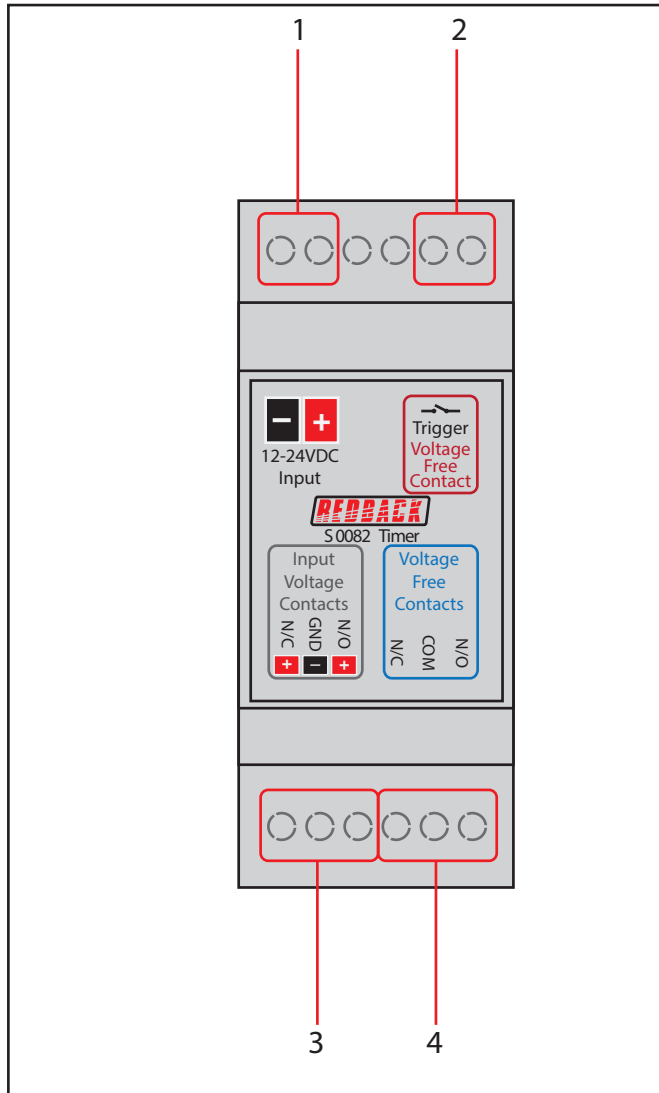

Fig 1

Figure 2 shows the location of the DIP switches.

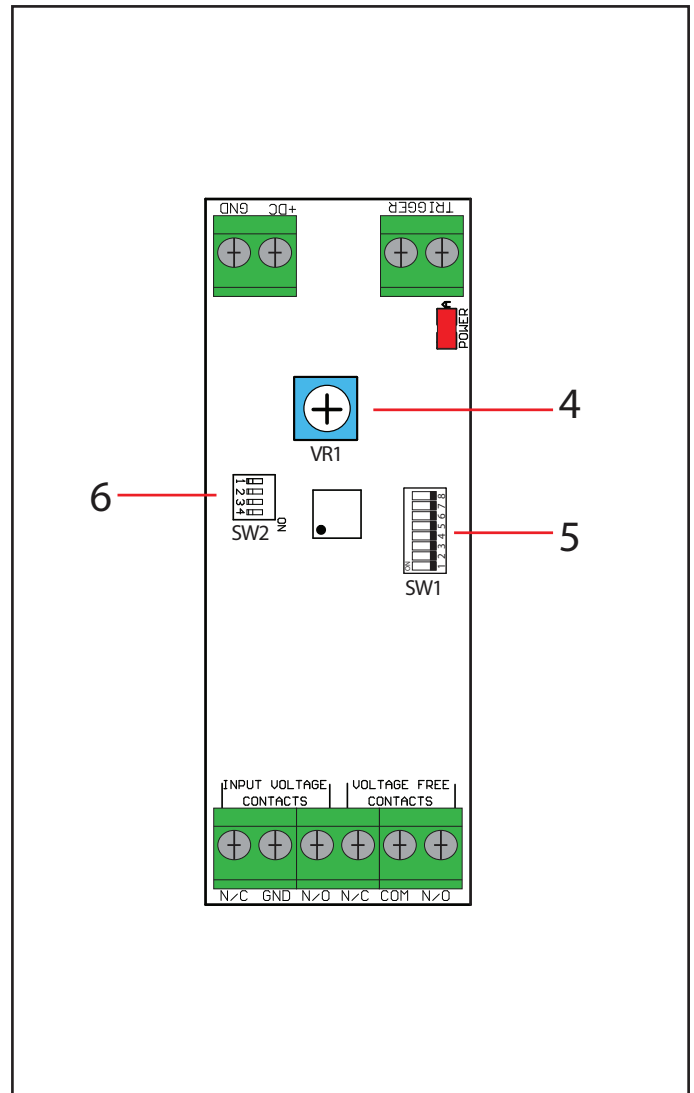

Fig 2

- 1) Power Input - the S 0082 can be powered by a 12V DC to 24V DC supply.
- 2) Trigger Contacts - These are the contacts for triggering the timer. The contacts are voltage free and only require a short to trigger the unit.
- 3) Input Voltage contacts - These terminals provide a voltage output when the timer is activated. The output voltage is determined by the input voltage supplied to the timer. i.e. if the input voltage of the S 0082 is 12V DC, then the output voltage when activated will be 12V DC.
The output terminals have a N/O (normally open), N/C (normally closed) and a ground connection. In this configuration the output voltage appears between the N/O and ground terminals when this output is activated. When this output is not active, the output voltage appears between the N/C and ground terminals. Note: The maximum current draw through these terminals is 5 amps.
- 4) Voltage Free Contacts - These terminals provide a closing contact when the timer is activated.
The output terminals have a N/O (normally open), N/C (normally closed) and a ground connection. In this configuration a short circuit appears between the N/O and ground terminals when this output is activated. When this output is not active, a short circuit appears between the N/C and ground terminals.

The S 0082 timer settings are configured by DIP SW1 and the trimpot VR1 shown in fig 2. To access these remove the top cover with a small flat blade screwdriver.

- 4) Trimpot VR1 - This is used to adjust the time duration. This is adjustable from 1 - 60 seconds, 1 - 60 minutes or 1 - 24 hours depending on the settings of DIP SW1.
- 5) DIP SW 1 - sets the timer options including, time adjustment, timer activation, trigger options etc. See DIP switch settings below.
- 6) DIP SW 2 - not used.

IMPORTANT NOTE:
Ensure power is switched off when adjusting DIP switches.
New settings will be effective when power is switched back on.

5.0 DIP SW1 settings

The actual duration the S 0082 is active is set by switches 1 and 2 and VR1.

- Switch 1 - OFF**
Switch 2 - OFF

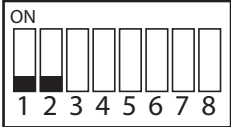

Time adjusted between 1 and 60 seconds. Adjustable by VR1.
- Switch 1 - ON**
Switch 2 - OFF

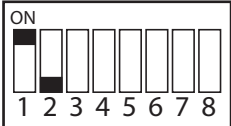

Time adjusted between 1 and 60 minutes. Adjustable by VR1.
- Switch 1 - Not Used**
Switch 2 - ON

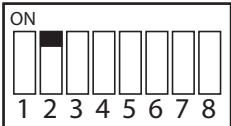

Time adjusted between 1 and 24 hours. Adjustable by VR1.

The timer can be activated by either the trigger or simply by power being applied. This is set via switch 3.

- Switch 3 - OFF**

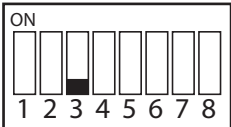

Timer activated by shorting the trigger contacts together.
- Switch 3 - ON**

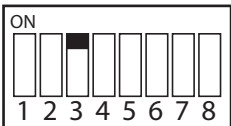

Timer activated by applying power.

The outputs can be set to activate when the timer starts or activate when the timer finishes. This is set via switch 4.

- Switch 4 - OFF**



Outputs activate when the timer starts.
- Switch 4 - ON**



Outputs activate when the timer finishes.

The timer can be activated by either the trigger being closed or by the trigger being released. This is set via switch 5.

Switch 5 - OFF

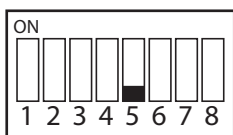

Timer activated by shorting the trigger contacts together.

Switch 5 - ON

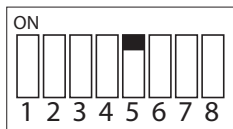

Timer activated by releasing the trigger contacts.

Once the timer has been activated it can be cancelled by closing the trigger contact for more than 3 seconds. This is set via switch 6.

Switch 6 - OFF

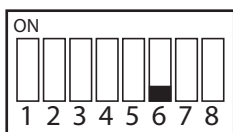

No cancel option.

Switch 6 - ON



Active timer will be cancelled when trigger contact closed for more than 3 seconds.

The outputs of the timer can be set to toggle their output according to the time set by switches 1 and 2. i.e. If the time duration was set to 5 seconds the outputs would toggle ON and OFF every 5 seconds. Note: this mode only functions when the timer is activated by applying power (see switch 3 settings).

Switch 7 - OFF

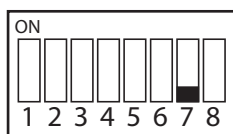

No toggle output.

Switch 7 - ON

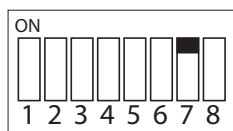

Outputs will toggle ON and OFF while power is applied.

The outputs of the timer can be set to toggle their output according to the time set by switches 1 and 2. i.e. If the time duration was set to 5 seconds the outputs would toggle ON and OFF every 5 seconds. Note: this mode only functions when the timer is activated by closing the trigger contact (see switch 3 settings).

Switch 8 - OFF

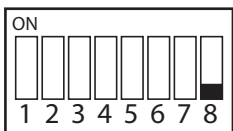

No toggle output.

Switch 8 - ON

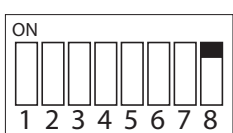

Outputs will toggle ON and OFF while the trigger is closed.