

## Product Guide

**C 2118B** 200mm (8") 100V 15W High Power Twin Cone Driver



# C 2118B Twin Cone High Power Public Address EWIS Driver

- ✓ High power 15W output for increased SPL
- ✓ Excellent speech intelligibility
- ✓ Offset transformer mounting for installations with limited recess space.
- ✓ High quality speaker driver developed for BGM, paging and emergency warning applications
- ✓ Fitted with 4 way wire protect terminal block for loop in, loop out wiring as required by Australian Standards.
- ✓ Fitted with supervisory capacitor for line monitoring.
- ✓ 5 year warranty.



### Application

The C 2118B is designed for EWIS (fire & evacuation) installations. It is ideal for BGM, paging & emergency warning applications. The offset transformer mounting allows mounting in ceilings with limited recess space.

### Emergency Warning & Intercommunications Systems (EWIS)

This speaker is designed for use in installations designed to deliver both verbal and tone announcements to occupants for evacuation and alarm conditions.

It is fitted with line monitoring capacitor and 4 way wire protect terminal connection.

### About Redback® Speaker Drivers

Each custom designed speaker and transformer combination has been specifically engineered to ensure a wide frequency range and dispersion angle, plus a high sound pressure level (SPL) ensuring excellent music and speech intelligibility; which is highly desirable for emergency paging applications.

Redback® drivers exhibit optimum frequency response and efficiency for BGM, paging and EWIS applications. The transformers are wound on professional grade grain oriented steel cores for high efficiency and extended frequency response.

Each transformer is fitted with multiple power tapings which are selected via a tab on the top of the transformer.

### Testing

Redback® drivers are subject to strenuous factory testing reducing the risk of unit failure or performance reduction over time. Each driver has a power rating well above the max tapping of the transformer, ensuring reliable operation and excellent longevity.

### Installation Guidelines

The C 2118B is fitted with a 4 way wire protect screw terminal block. This is suitable for loop in, loop out cabling.

To attach the driver to a speaker grille use C 0835 grille fixing clips. For installation in gypsum or plasterboard ceilings use C 0825 Gypsee® screws. See "additional installation accessories" over the page.

## Product Guide

**C 2118B** 200mm (8") 100V 15W High Power Twin Cone Driver



### Dimensions & Transformer Detail

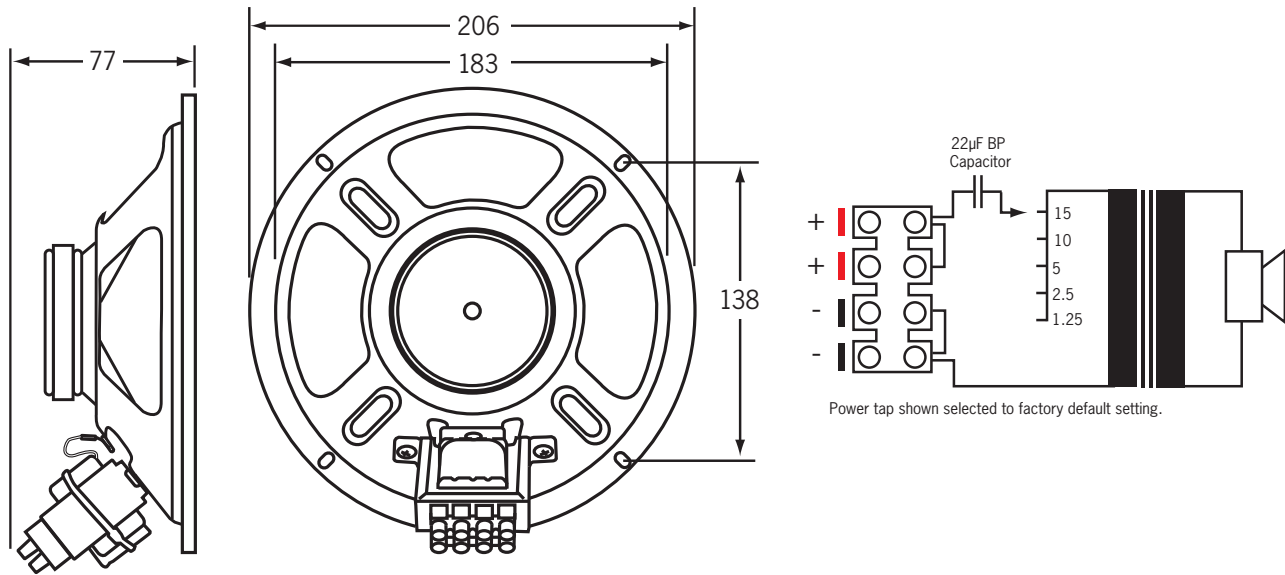

### Specifications

#### Electrical

Power taps:	1.25, 2.5, 5, 10, 15W
SPL 1W @ 1m:	92dB @ 1kHz (+/- 2dB)
Frequency response:	55Hz-15kHz
Connection:	4 way terminal block + 22uF bipolar capacitor

#### Mechanical

Driver construction:	Twin paper cone
Ceiling cutout:	183mm
Mounting depth:	77mm
Overall weight:	910g

#### Environmental

Operating temperature:	-25°C to +55°C
Relative humidity:	< 95%

#### Additional Installation Accessories

- C 0805** 200mm (8") white slimline ceiling grille
- C 0835** Pk100 speaker grille fixing clips
- C 0825** Pk100 Gypsee® gypsum/plasterboard screws

### Architect Specifications

The speaker shall be of 200mm diameter and be fitted with a 100V transformer with power taps of 15W, 10W, 5W, 2.5W and 1.25W. It shall have a SPL of 92dB. The transformer shall be fitted with a 4 way wire protect terminal block for cable connection and 22uf bipolar capacitor for line monitoring. The speaker shall be a Redback model C 2118B.